



**E SERIES
PROPORTIONAL PRESSURE CONTROLS
Pilot Relief / Relief / Reducing and Relieving**

**PROPORTIONAL
CONTROLS**

Up to 24.5 MPa (3550 PSI), 400 L/m in (106 U.S.GPM)

Proportional pressure control valves control the system pressure proportionally through a controlled input current from the amplifier. Therefore, the continuous and stepless pressure control can be obtained even with a single valve. The valves are of help not only to simplify the system design but also to eliminate any shocks in the hydraulic system.

■ **Pilot Relief Valves.....**

Page 4
These valves are composed of a small DC solenoid and a direct-acting type relief valve. As a relief valve for a hydraulic system of small flow capacity or a pilot valve to electro-hydraulic proportional control valves, the valves are able to control the pressure in proportion to an input current.

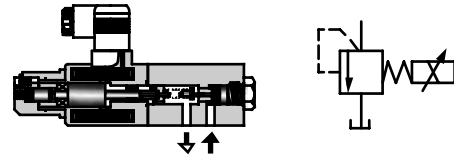

■ **Relief Valves.....**

Page 11
These valves consist of a small size but high performance 1/8 electro-hydraulic proportional pilot relief valve and a relief valve specially developed as low noise type. The valves can control the pressure in a hydraulic system proportionally through a controlled input current.

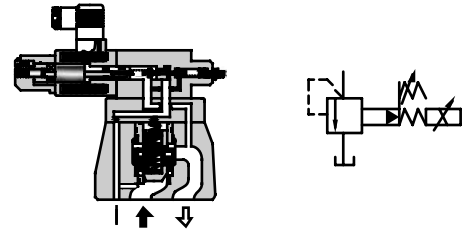

■ **Reducing and Relieving Valves.....**

Page 21
These valves consist of a small size but high performance 1/8 electro-hydraulic proportional pilot relief valve and a reducing valve with relief function. The valves can control the pressure in a hydraulic system proportionally through a controlled input current. As the valves have a relieving mechanism, a good response speed in reducing the pressure even at a large load capacity can be obtained.

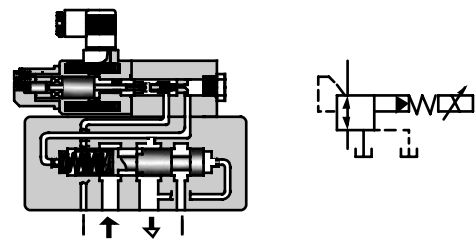

■ Hydraulic Fluids

● Fluid Types

Any type of hydraulic fluid listed in the table below can be used.

Petroleum Base Oils	Use fluids equivalent to ISO VG 32 or VG 46.
Synthetic Fluids	Use phosphate ester or polyol ester fluids. When phosphate ester fluid is used, prefix "F-" to the model number because the special seals (fluororubber) are required to be used.
Water-containing Fluids	Use water-glycol fluid.

Note: For use with hydraulic fluids other than those listed above, please consult your Yuken representatives in advance.

● Recommended Fluid Viscosity and Temperature

Use hydraulic fluids which satisfy the both recommended viscosity and oil temperatures given in the table below.

Name	Viscosity	Temperature
Pilot Relief Valves Relief Valves Reducing and Relieving Valves	15 - 400 mm ² /s (77 - 1800 SSU)	-15 - +70°C (5 - 160°F)

● Control of Contamination

Due caution must be paid to maintaining control over contamination of the hydraulic fluids which may otherwise lead to breakdowns and shorten the life of the valve. Please maintain the degree of contamination within NAS 1638-Grade 11. Use 20 μm or finer line filter.

Instructions

■ Mounting

Be sure that the air vent faces up.

In addition, if the valve is mounted vertically, the minimum adjustment pressure is 2 MPa (290 PSI) or higher.

[Good example]

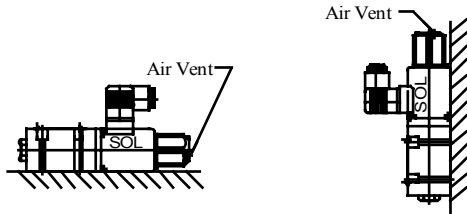

[Bad example]

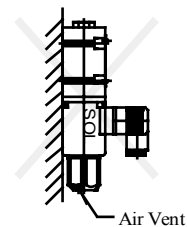

■ Air Bleeding

To ensure stable control, bleed the air from solenoid completely and fill its core with oil.

Bleeding can be done by slowly loosening one of the air vents at the end of the solenoid. Choose one of the three air vents which is expected to work most effectively (see the figure to the right).

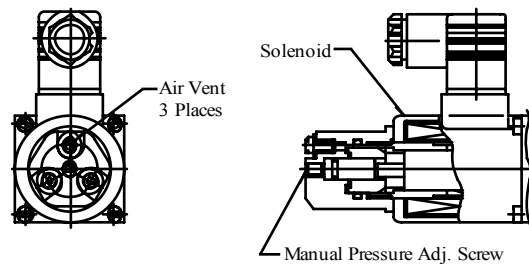

■ Manual Adjustment Screw

When initial adjustments are to be made or when no current is supplied to the valve due to electrical failure or other problem, turn the manual pressure adjustment screw to temporarily set the valve pressure. In that case, when turn the manual pressure adjustment screw clockwise, the valve pressure rises. Under normal condition, however, this screw must be kept in its original position (see the figure to the right).

■ Tank and Drain Piping

The tank-line back pressure and drain back pressure directly affect the minimum adjustment pressure. Therefore, do not connect the tank or drain pipes to other lines, but connect them directly to the reservoir maintaining the back pressure as low as possible. Be sure that the tank and drain pipe ends are immersed in fluid.

■ Hysteresis and Repeatability Value Indications

The hysteresis and repeatability values indicated in the specifications for each control valve are determined under the following conditions:

- Hysteresis Value: Obtained when Yuken's applicable power amplifier is used.
- Repeatability Value: Obtained when Yuken's applicable power amplifier is used under the same conditions.

10 Ω Series Solenoid



Specifications / Model Number Designation

■ Specifications

Model Numbers	EDG-01
Description	EDG-01
Max. Operating Pres.	24.5 MPa (3550 PSI)
Max. Flow	2 L/min (.53 U.S.GPM)
Min. Flow	0.3 L/min (.08 U.S.GPM)
Pressure Adj. Range MPa (PSI)	Refer to Model Number Designation
Rated Current	EDG-01*-B 800 mA EDG-01*-C 900 mA EDG-01*-H 950 mA
Coil Resistance	10 Ω
Hysteresis	Less than 3%
Repeatability	Less than 1%
Approx. Mass	2 kg (4.4 lbs.)

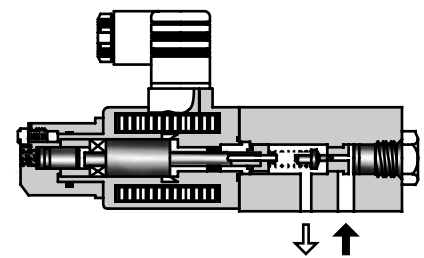

■ Model Number Designation

ED	G	-01	V	-C	-1	-PN	T13	-51	*
Series Number	Type of Mounting	Valve Size	Applicable Control ^{★1}	Pressure Adj. Range MPa (PSI)	Safety Valve	P-Line Orifice	T-Line ^{★2} Orifice	Design Number	Design Standards
ED: Proportional Electro-Hydraulic Pilot Relief Valve	G: Sub-plate Mounting	01	None: General use V: Vent Control of Relief Valve (Omit if not required)	B: 0.5 - 6.9 (70 - 1000)	None: Without Safety Valve 1: With Safety Valve	PN: Without Orifice (Standard)	T15	51	Refer to ^{★3}
				C: 1.0 - 15.7 (145 - 2275)			T13		
				H: 1.2 - 24.5 (175 - 3550)			T11		

★ 1. When the valve is to be used for vent control purpose, orifice adjustment is required due to piping capacity limitations. Therefore, consulty our Yuken representative in advance.

★ 2. The orifice used as the pilot valve may differ from the standard orifice.

★ 3. Design Standards: None Japanese Standard "JIS" and European Design Standard
90 N. American Design Standard

Graphic Symbols

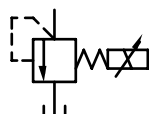

Without Safety Valve

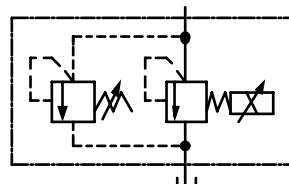

With Safety Valve

Sub-plate / Instructions / Others

■ Attachment

● Mounting Bolts

Four socket head cap screws in the table below are included.

Descriptions	Soc. Hd. Cap Screw
Japanese Standard "JIS" European Design Standard	M5 ×45 Lg.
N. American Design Standard	No. 10 - 24 UNC ×1-3/4 Lg.

■ Applicable Power Amplifier

For stable performance, it is recommended that Yuken's applicable power amplifiers be used (for details see Catalogue No. Pub. EC-1305).

Model Numbers: AME-D-10-*****-20

AME-D2-1010-*****-10

SK1022-*****-*****-11

SK1015-11 (For DC power supply)

AMN-D-10 (For DC power supply)

■ Sub-plate

Piping Size	Japanese Standard "JIS"		European Design Standard		N. American Design Standard		Approx. Mass kg (lbs.)
	Sub-plate Model Numbers	Thread Size	Sub-plate Model Numbers	Thread Size	Sub-plate Model Numbers	Thread Size	
1/8	DSGM-01-30	Rc 1/8	DSGM-01-3080	1/8 BSP.F	DSGM-01-3090	1/8 NPT	0.8 (1.8)
1/4	DSGM-01X-30	Rc 1/4	DSGM-01X-3080	1/4 BSP.F	DSGM-01X-3090	1/4 NPT	0.8 (1.8)
3/8	DSGM-01Y-30	Rc 3/8	—	—	DSGM-01Y-3090	3/8 NPT	0.8 (1.8)

- Sub-plates are available. Specify the sub-plate model number from the table above. When sub-plates are not used, the mounting surface should have a good machined finish.

■ Instructions

● Tank-Line Back Pressure

Check that the tank line back pressure does not exceed 0.2 MPa (29 PSI).

● Vent Control

When the valve is used for vent control of relief valves or others, use the pipes of 6 mm (.24 in.) ID. 300 mm (11.8 in.) or less length for connection.

If the pressure is instable, provide a 1 to 1.5 mm (.04 to .06 in.) diameter orifice to the vent port of the relief valves or others.

● Circuit Pressure Control

When the pressure in a circuit is directly controlled with this valve, set the trapped oil volume being more than 40 cm³ (2.44 cu. in.).

● Safety Valve Pressure Setting

The pressure of the safety valve at the maximum flow is preset at the value equal to the upper limit of the pressure adjustment range plus 2 MPa (290 PSI).

In case where the upper limit of operating pressure is low or the upper limit of flow rate to be used is different from the specified maximum flow, please adjust and determine the setting pressure of the safety valve at the value calculated from the following formula.

$$\text{Setting pressure} = (\text{Operating pressure upper limit}) + (\text{Additional pressure indicated below})$$

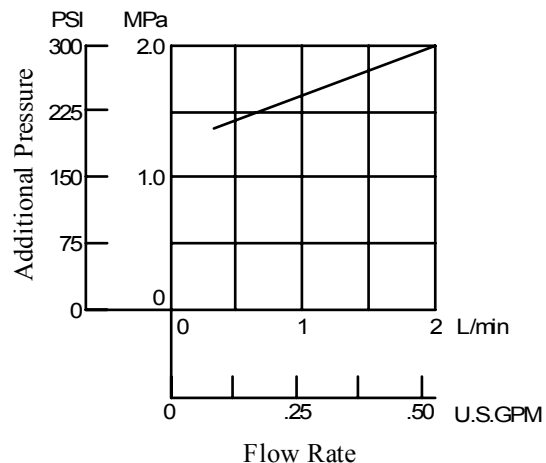

To lower the setting pressure, turn the safety valve pressure adjustment screw anti-clockwise. After adjustment, be sure to tighten the lock nut.

Installation Drawing

EDG-01*-*-1-PNT*-51/5190

With Safety Valve

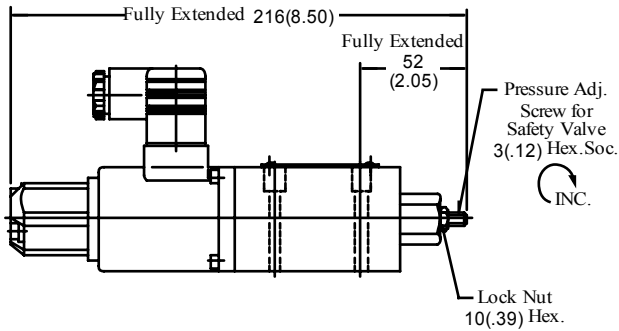

• For other dimensions, refer to the without safety valve.

EDG-01*-*-PNT*-51/5190

Without Safety Valve

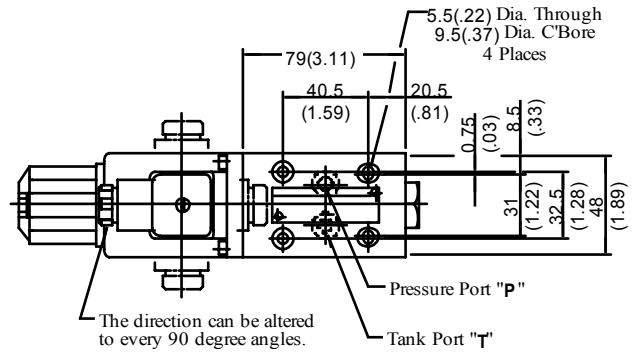

DIMENSIONS IN
MILLIMETRES (INCHES)

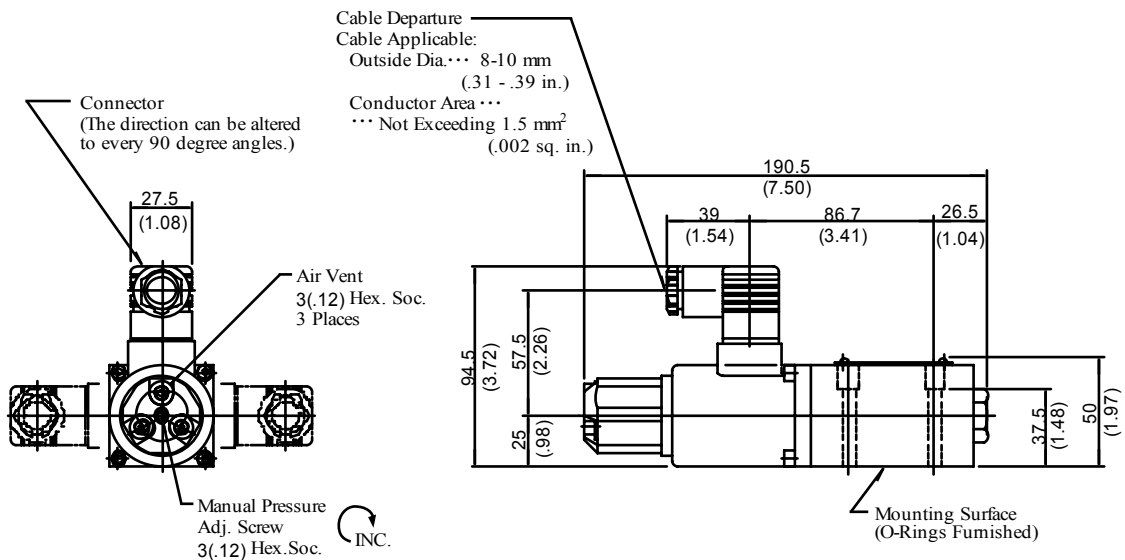

■ Sub-plates

DSGM-01*-30/3080/3090

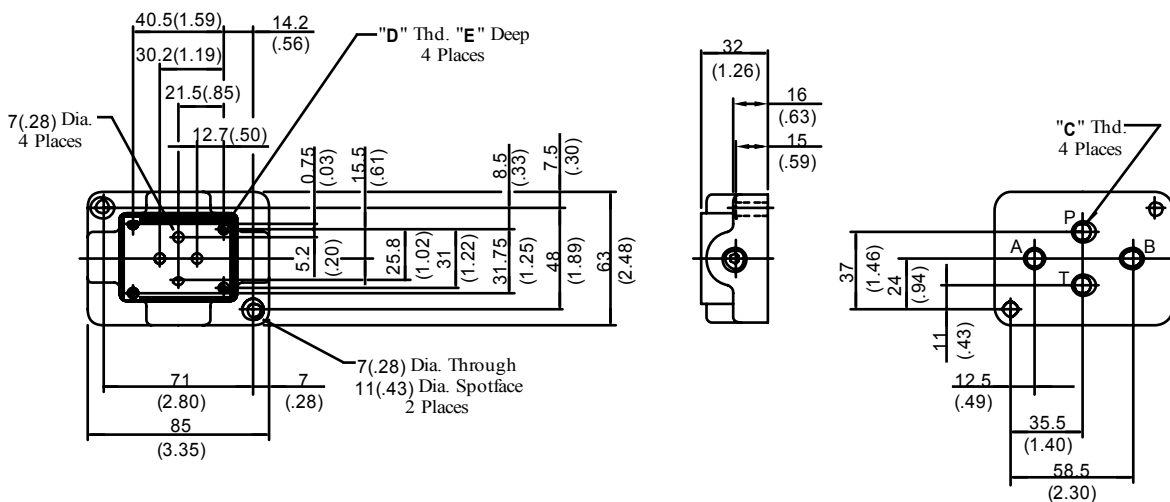

DIMENSIONS IN
MILLIMETRES (INCHES)

Sub-plate Model Numbers	Thread Size		"E" mm (in.)
	"C" Thd.	"D" Thd.	
DSGM-01-30	Rc 1/8	M5	10 (.39)
DSGM-01-3080	1/8 BSP.F		
DSGM-01-3090	1/8 NPT	No.10-24 UNC	12 (.47)
DSGM-01X-30	Rc 1/4	M5	10 (.39)
DSGM-01X-3080	1/4 BSP.F		
DSGM-01X-3090	1/4 NPT	No.10-24 UNC	12 (.47)
DSGM-01Y-30	Rc 3/8	M5	10 (.39)
DSGM-01Y-3090	3/8 NPT	No.10-24 UNC	12 (.47)



Typical Performance Characteristics

Step Response (Example)

These Characteristics have been obtained by measuring on each valve. Therefore, they may vary according to a hydraulic circuit to be used.

Flow Rate : 2 L/min (.53 U.S. GPM)
Trapped Oil Volume: 40 cm³ (2.44 cu. in.)
Viscosity : 30 mm²/s (141 SSU)

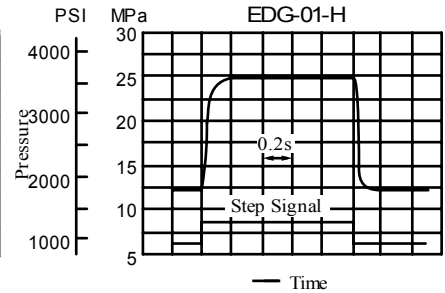
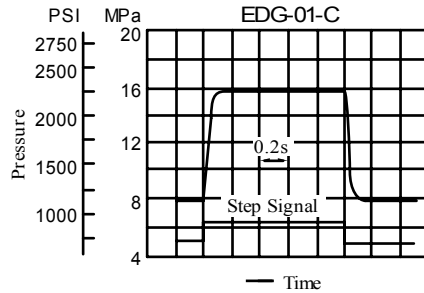
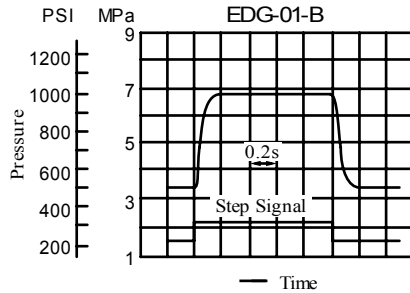

Frequency Response

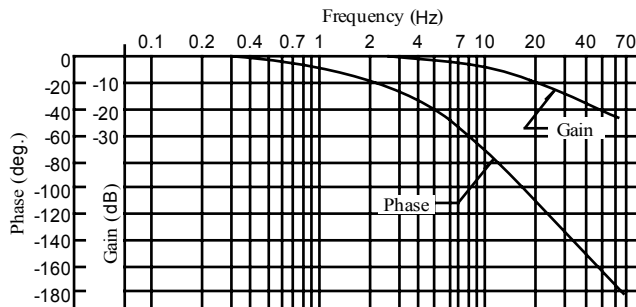

Flow Rate : 2 L/min (.53 U.S. GPM)
Pressure : 7.8 ± 1.6 MPa (1130 ± 230 PSI)
Trapped Oil Volume: 30 cm³ (1.83 cu. in.)
Viscosity : 30 mm²/s (141 SSU)

Control Pressure vs. Input Current

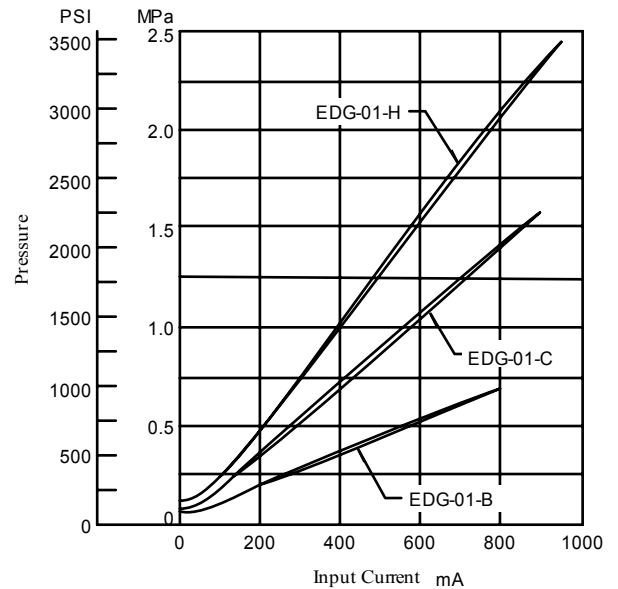

Min. Adjustment Pressure

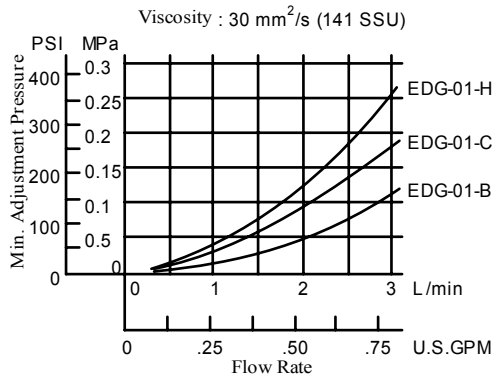

Flow Rate vs. Pressure

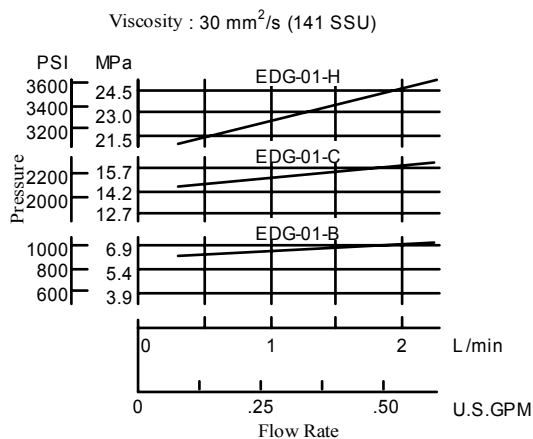

Viscosity vs. Pressure

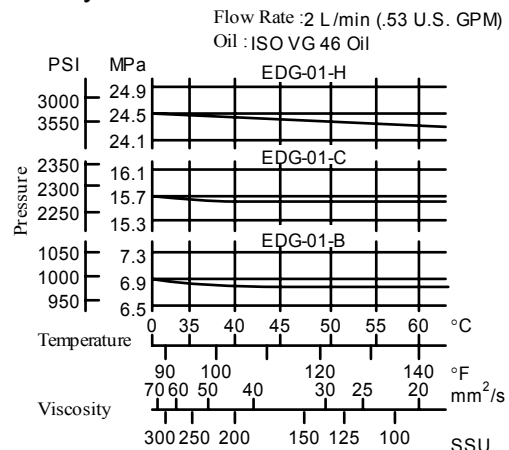

Spare Parts List and Pilot Valves

● Without Safety Valve

EDG-01*-*-PNT*-51/5190

EDG-01V*-*-PNT*-5103

EDG-01*-*-PNT*-5101

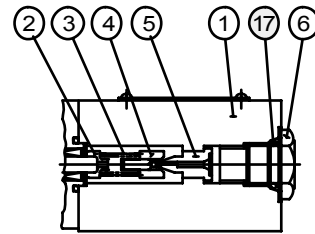
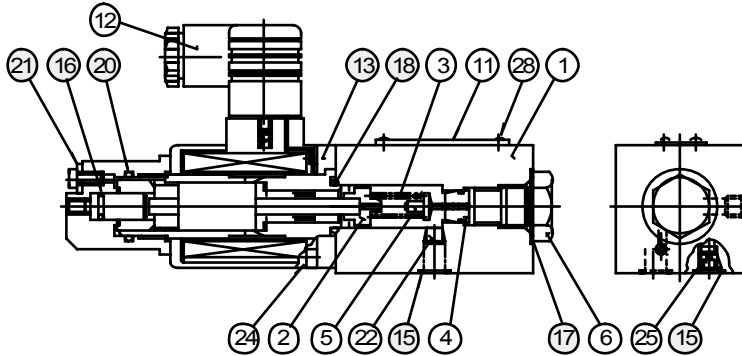

● With Safety Valve

EDG-01*-*-1-PNT*-51/5190

EDG-01V*-*-1-P*T*-5103

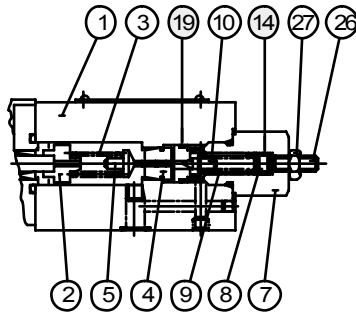

● List of Seals

Item	Name of Parts	Part Numbers	Qty.	Remarks
14	O-Ring	SO-NA-P6	1	Included in Seal Kit Kit No.: KS-EDG-01-51
15	O-Ring	SO-NB-P9	2	
16	O-Ring	SO-NB-P7	1	
17	O-Ring	SO-NB-P14	1	
18	O-Ring	SO-NB-P18	1	
19	O-Ring	SO-NB-A013	1	
20	O-Ring	SO-NB-P22	1	
21	Fastener Seal	SO-FCF-4	1	

Note) O-ring (Item 16, 18, 20) and the fastener seal (Item 21) are included in the solenoid assembly.

● Solenoid Ass'y

Valve Model Numbers	⑬ Solenoid Ass'y
EDG-01*-*-PNT*-51/5190 EDG-01*-*-PNT*-5101	E318-Y06M1-28-61
EDG-01V*-*-PNT*-51/5190	E318-Y06M1-05-61
EDG-01V*-*-P*T*-5103	E318-Y06M1-04-61

Note) The connector assembly GDM-211-B-11 (Item 12) is not included in the solenoid assembly.



CAUTION

When making replacement of seals, please do it carefully after reading through the relevant instructions in the Operator's Manual.

■ Pilot Valves

The table shows the proportional control valves (main valves) and corresponding pilot relief valves to be used onto the main valves.

Main Valve Model Numbers	Pilot Valve Model Numbers
EBG-03-C-51/5190	EDG-01V-C-1-PNT09-51
EBG-03-H-51/5190	EDG-01V-H-1-PNT09-51
EBG-03-C-T-51/5190	EDG-01V-C-PNT09-51
EBG-03-H-T-51/5190	EDG-01V-H-PNT09-51
EBG-06-C-51/5190	EDG-01V-C-1-PNT10-51
EBG-06-H-51/5190	EDG-01V-H-1-PNT10-51
EBG-06-C-T-51/5190	EDG-01V-C-PNT10-51
EBG-06-H-T-51/5190	EDG-01V-H-PNT10-51
EBG-10-C-51/5190	EDG-01V-C-1-PNT11-5103
EBG-10-H-51/5190	EDG-01V-H-1-PNT11-5103
EBG-10-C-T-51/5190	EDG-01V-C-PNT11-5103
EBG-10-H-T-51/5190	EDG-01V-H-PNT11-5103
ERBG-06-B-51/5190	EDG-01-B-PNTN-5101
ERBG-06-C-51/5190	EDG-01-C-PNTN-5101
ERBG-06-H-51/5190	EDG-01-H-PNT15-5101
ERBG-10-B-51/5190	EDG-01-B-PNTN-5101
ERBG-10-C-51/5190	EDG-01-C-PNTN-5101
ERBG-10-H-51/5190	EDG-01-H-PNT15-5101
EFBG-10-500-C-17/1790	EDG-01V-C-1-P18T17-5103
EFBG-10-500-H-17/1790	EDG-01V-H-1-PNT13-5103
EFBG-10-500-C-*-51/5190	EDG-01V-C-1-PNT12-5103
EFBG-10-500-H-*-51/5190	EDG-01V-H-1-PNT12-5103
EFBG-06-500-C-*-51/5190	EDG-01V-C-1-PNT11-5103
EFBG-06-500-H-*-51/5190	EDG-01V-H-1-PNT11-5103

Interchangeability between Current and New

■ Interchangeability between Current and New Design

EDG-01 series valve has changed model from 50 to 51 design in line with the solenoid improvement.

● Specifications and Characteristics

No change in specifications and characteristics between current and new design.

● Mounting Interchangeability

There is an interchangeability in the mounting dimensions, however, the outside shape and dimensions are changed as shown below due to solenoid improvement and other modifications.

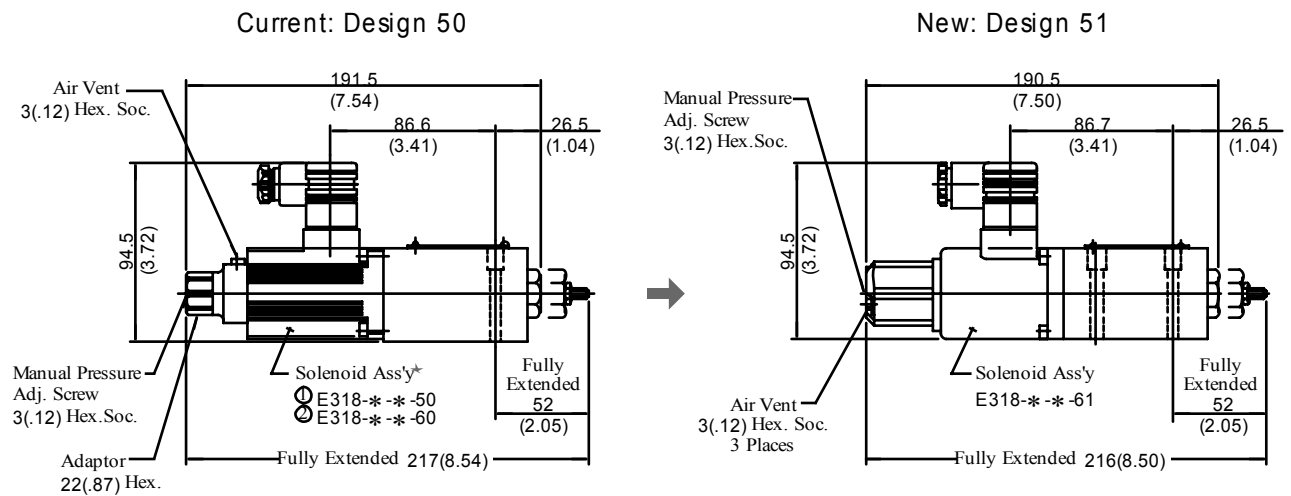

★The solenoid assembly current design comes in two types ① E318-50 design and ② 60 design. See the figure on the left for an external view of type ①. See the figure on the right for type ②.

Specifications / Model Number Designation

■ Specifications

Model Numbers Description	EBG-03	EBG-06	EBG-10
Max. Operating Pres. MPa (PSI)	24.5 (3550)	24.5 (3550)	24.5 (3550)
Max. Flow L/min(U.S.GPM)	100 (26.4)	200 (52.8)	400 (106)
Min. Flow L/min(U.S.GPM)	3 (.79)	3 (.79)	3 (.79)
Pressure Adjustment Range MPa (PSI)	Refer to Model Number Designation		
Rated Current	C: 770 mA H: 820 mA	C: 750 mA H: 800 mA	C: 730 mA H: 780 mA
Coil Resistance	10 Ω	10 Ω	10 Ω
Hysteresis	Less than 3%	Less than 3%	Less than 3%
Repeatability	Less than 1%	Less than 1%	Less than 1%
Approx. Mass kg (lbs.)	5.6 (12.3)	6.3 (13.9)	10 (22)

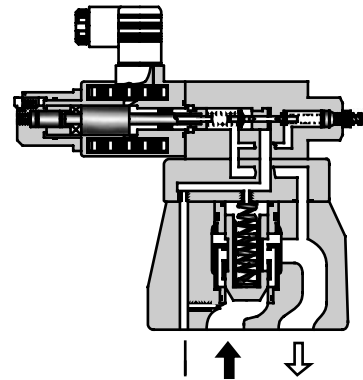

■ Model Number Designation

EB	G	-03	-C	-T	-51	*
Series Number	Type of Mounting	Valve Size	Pres. Adj. Range MPa (PSI)	Safety Valve	Design Number	Design Standards
EB : Proportional Electro-Hydraulic Relief Valve	G : Sub-plate Mounting	03	^{★1} C : * - 15.7 (* - 2275) ^{★1} H : * - 24.5 (* - 3550)	None: With Safety Valve T : Without Safety Valve	51	Refer to ★ 2
		06				
		10				

★ 1. Min. adjustment pressure shall be referred to the curves on page 16.

★ 2. Design Standards: None Japanese Standard "JIS" and European Design Standard
 90 N. American Design Standard

Graphic Symbols

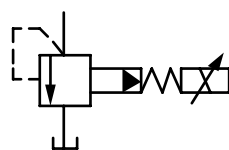

Without Safety Valve

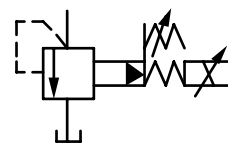

With Safety Valve

■ Attachment

● Mounting Bolts

Valve Model Numbers	Socket Head Cap Screw		
	Japanese Standard "JIS" & European Design Standard	N. American Design Standard	Qty.
EBG-03	M12 ×40 Lg.	1/2 - 13 UNC ×1-1/2 Lg.	4
EBG-06	M16 ×50 Lg.	5/8 - 11 UNC ×2 Lg.	4
EBG-10	M20 ×60 Lg.	3/4 - 10 UNC ×2-1/4 Lg.	4

■ Applicable Power Amplifiers

For stable performance, it is recommended that Yuken's applicable power amplifiers be used (for details see Catalogue No. Pub. EC-1305).

Model Numbers: AME-D-10-**-20 SK1015-11 (For DC power supply)
 AME-D2-1010-**-10 AMN-D-10 (For DC power supply)
 SK1022-**-**-11

■ Sub-plate

Valve Model Numbers	Japanese Standard "JIS"		European Design Standard		N. American Design Standard		Approx. Mass kg (lbs)
	Sub-plate Model Numbers	Thread Size	Sub-plate Model Numbers	Thread Size	Sub-plate Model Numbers	Thread Size	
EBG-03	BGM-03-20	Rc 3/8	BGM-03-3080	3/8 BSP.F	BGM-03-2090	3/8 NPT	2.4 (5.3)
	BGM-03X-20	Rc 1/2	BGM-03X-3080	1/2 BSP.F	BGM-03X-2090	1/2 NPT	3.1 (6.8)
EBG-06	BGM-06-20	Rc 3/4	BGM-06-3080	3/4 BSP.F	BGM-06-2090	3/4 NPT	4.7 (10.4)
	BGM-06X-20	Rc 1	BGM-06X-3080	1 BSP.F	BGM-06X-2090	1 NPT	5.7 (12.6)
EBG-10	BGM-10-20	Rc 1-1/4	BGM-10-3080	1-1/4 BSP.F	BGM-10-2090	1-1/4 NPT	8.4 (18.5)
	BGM-10X-20	Rc 1-1/2	BGM-10X-3080	1-1/2 BSP.F	BGM-10X-2090	1-1/2 NPT	10.3 (22.7)

● Sub-plates are available. Specify the sub-plate model number from the table above. When sub-plates are not used, the mounting surface should have a good machined finish.

■ Instructions

● Safety Valve

The pressure of the safety valve for EBG-03 is preset at the value equal to the upper limit of the pressure adjustment range plus 2 MPa (290 PSI) subject to a flow rate of 50 L/min (13.2 U.S.GPM).

The same for EBG-06 is preset at the value equal to the upper limit of the pressure adjustment range plus 3.5 MPa (510 PSI) subject to a flow rate of 100 L/min (26.4 U.S.GPM).

The same for EBG-10 is preset at the value equal to the upper limit of the pressure adjustment range plus 4 MPa (580 PSI) subject to a flow rate of 200 L/min (52.8 U.S.GPM).

In case where the upper limit of operating pressure is low or the upper limit of flow rate to be used is different from the specified maximum flow, please adjust and determine the setting pressure of the safety valve at the value calculated from the following formula.

$$\text{Setting pressure} = (\text{Operating pressure upper limit}) + (\text{Additional pressure indicated blow})$$

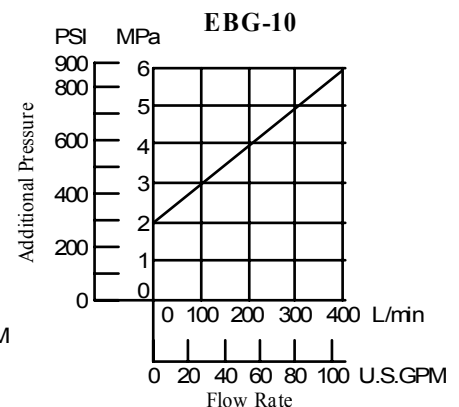
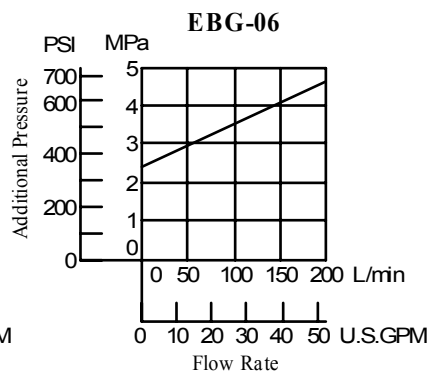
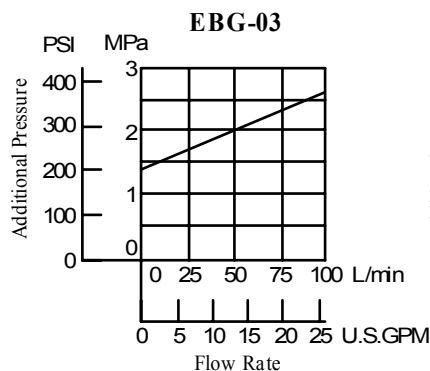

To lower the setting pressure, turn the safety valve pressure adjustment screw anti-clockwise. After adjustment, be sure to tighten the lock nut.

Installation Drawing

EBG-⁰³/₀₆-*-51/5190

With Safety Valve

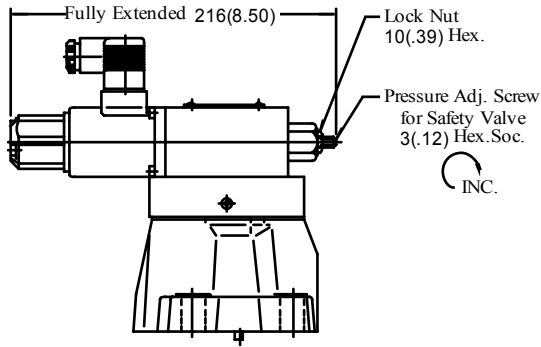

• For other dimensions, refer to the without safety valve.

Mounting Surface
EBG-03 : ISO 6264-AR-06-2-A
EBG-06 : ISO 6264-AS-08-2-A

DIMENSIONS IN
MILLIMETRES (INCHES)

EBG-⁰³/₀₆-*-T-51/5190

Without Safety Valve

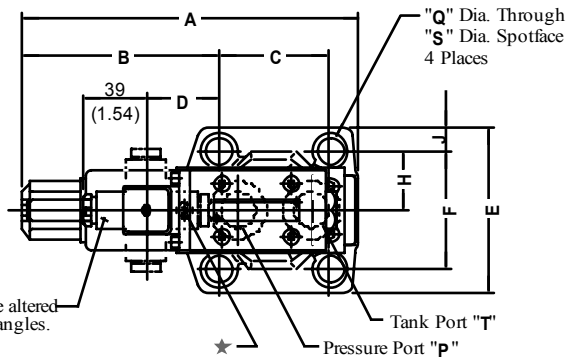

★ This port is not used. It is provided because of the common use of the body with the low-noise relief valve. On the sub-plate, plug the port which corresponds to this port.

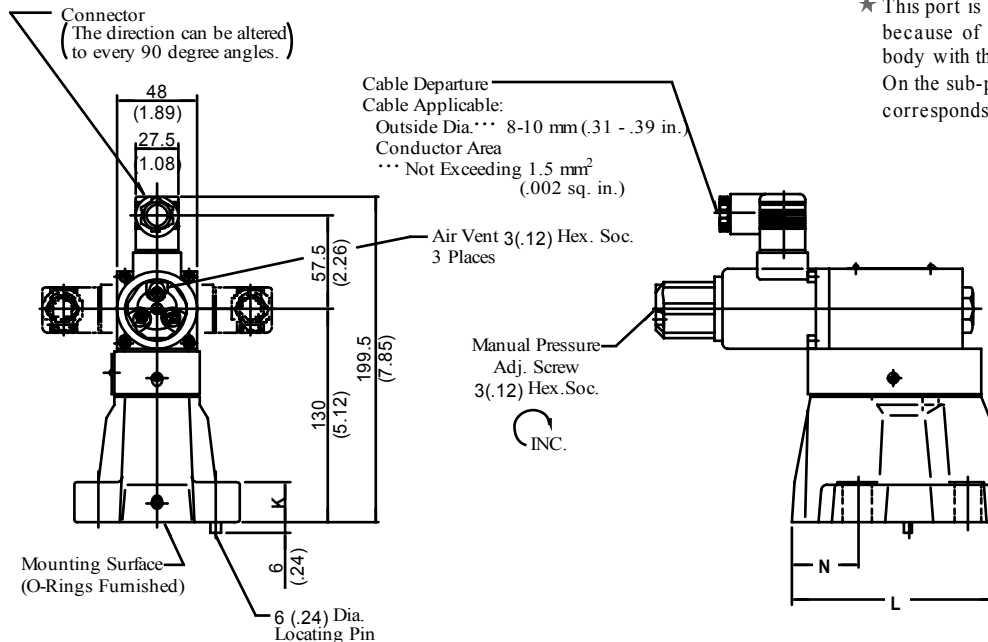

Model Numbers	Dimensions mm (Inches)												
	A	B	C	D	E	F	H	J	K	L	N	Q	S
EBG-03	197.5 (7.78)	117.6 (4.63)	53.8 (2.12)	40.3 (1.59)	76 (2.99)	53.8 (2.12)	26.9 (1.06)	11.1 (.44)	21.5 (.85)	106 (4.17)	26.1 (1.03)	13.5 (.53)	21 (.83)
EBG-06	205.5 (8.09)	119.5 (4.70)	66.7 (2.63)	42.2 (1.66)	98 (3.86)	70 (2.76)	35 (1.38)	14 (.55)	26 (1.02)	122 (4.80)	36 (1.42)	17.5 (.69)	26 (1.02)

Installation Drawing

Mounting surface:
ISO 6264-AT-10-2-A

EBG-10-* -51/5190

With Safety Valve

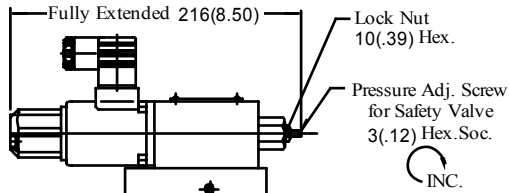

• For other dimensions, refer to the without safety valve.

DIMENSIONS IN
MILLIMETRES (INCHES)

EBG-10-* -T-51/5190

Without Safety Valve

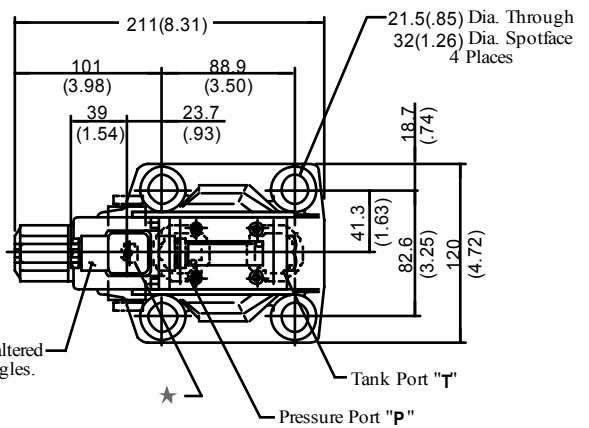

★ This port is not used. It is provided because of the common use of the body with the low-noise relief valve. On the sub-plate, plug the port which corresponds to this port.

Connector
(The direction can be altered to every 90 degree angles.)

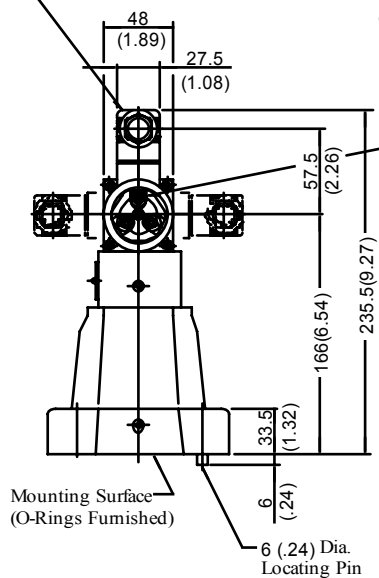

Cable Departure
Cable Applicable:
Outside Dia... 8-10 mm (.31 - .39 in.)
Conductor Area
... Not Exceeding 1.5 mm² (.002 sq. in.)

Air Vent
3(.12) Hex.Soc.
3 Places

Manual Pressure
Adj. Screw
3(.12) Hex.Soc.

INC.

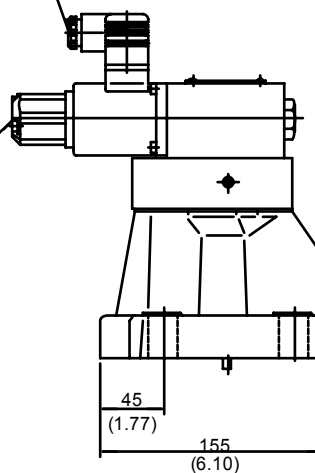

Installation Drawing

BGM-03,03X-20/3080/2090
Sub-plate: BGM-06,06X-20/3080/2090
BGM-10,10X-20/3080/2090

DIMENSIONS IN
MILLIMETRES (INCHES)

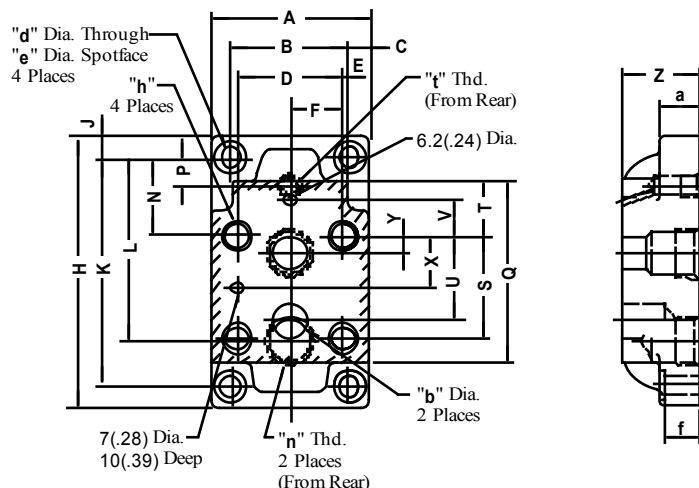

Model Numbers	Dimensions mm (Inches)													
	A	B	C	D	E	F	H	J	K	L	N	P	Q	S
BGM-03	86 (3.39)	60 (2.36)	13 (.51)	53.8 (2.12)	3.1 (.12)	26.9 (1.06)	149 (5.87)	13 (.51)	123 (4.84)	86 (3.39)	32 (1.26)	26 (1.02)	97 (3.82)	53.8 (2.12)
BGM-03X										95 (3.74)	21 (.83)			
BGM-06	108 (4.25)	78 (3.07)	15 (.59)	70 (2.76)	4 (.16)	35 (1.38)	180 (7.09)	15 (.59)	150 (5.91)	106.5 (4.19)	51 (2.01)	27.2 (1.07)	121 (4.76)	66.7 (2.63)
BGM-06X										119 (4.69)	18 (.71)			
BGM-10	126 (4.96)	94 (3.70)	16 (.63)	82.6 (3.25)	5.7 (.22)	41.3 (1.63)	227 (8.94)	16 (.63)	195 (7.68)	138.2 (5.44)	62 (2.44)	30.2 (1.19)	154 (6.06)	88.9 (3.50)
BGM-10X										158 (6.22)	17 (.67)			

Model Numbers	Dimensions mm (Inches)										
	T	U	V	X	Y	Z	a	b	d	e	f
BGM-03	19 (.75)	47.4 (1.87)	0 (0)	22 (.87)	22 (.87)	32 (1.26)	20 (.79)	14.5 (.57)	11 (.43)	17.5 (.69)	19 (.75)
BGM-03X						40 (1.57)					
BGM-06	37 (1.46)	55.5 (2.19)	23.8 (.94)	33.4 (1.31)	11 (.43)	40 (1.57)	25 (.98)	23 (.91)	13.5 (.53)	21 (.83)	24 (.94)
BGM-06X						50 (1.97)					
BGM-10	42 (1.65)	76.2 (3.00)	31.8 (1.25)	44.5 (1.75)	12.7 (.50)	50 (1.97)	32 (1.26)	28 (1.10)	17.5 (.69)	26 (1.02)	31 (1.22)
BGM-10X						63 (2.48)					

Model Numbers	Japanese Standard "JIS" Design "20"			European Design Standard Design "3080"			N. American Design Standard Design "2090"		
	"h"	"n" Thd.	"t" Thd.	"h"	"n" Thd.	"t" Thd.	"h"	"n" Thd.	"t" Thd.
BGM-03	M12 Thd.	Rc 3/8	Rc 1/4	M12 Thd.	3/8 BSP.F	1/4 BSP.F	1/2-13UNC Thd.	3/8 NPT	1/4 NPT
BGM-03X	20(.79) Deep	Rc 1/2		M12 Thd.	1/2 BSP.F		22(.87) Deep	1/2 NPT	
BGM-06	M16 Thd.	Rc 3/4		M16 Thd.	3/4 BSP.F		5/8-11UNC Thd.	3/4 NPT	
BGM-06X	25(.98) Deep	Rc 1		M16 Thd.	1 BSP.F		27(1.06) Deep	1 NPT	
BGM-10	M20 Thd.	Rc1-1/4		M20 Thd.	1-1/4 BSP.F		3/4-10UNC Thd.	1-1/4 NPT	
BGM-10X	28(1.10) Deep	Rc 1-1/2	M20 Thd.	1-1/2 BSP.F	28(1.10) Deep	1-1/2 NPT			

Typical Performance Characteristics

■ Min. Adjustment Pressure

Viscosity : 30 mm²/s (141 SSU)

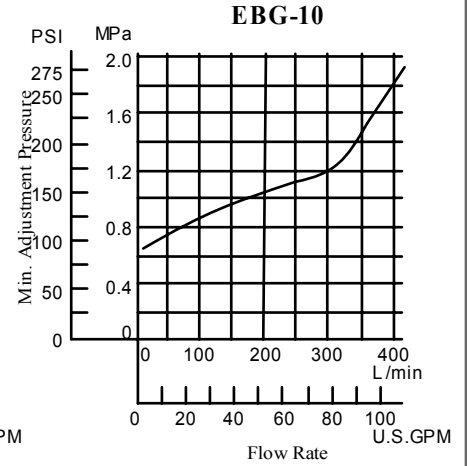
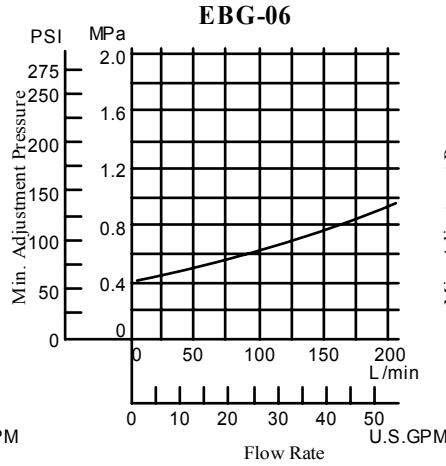
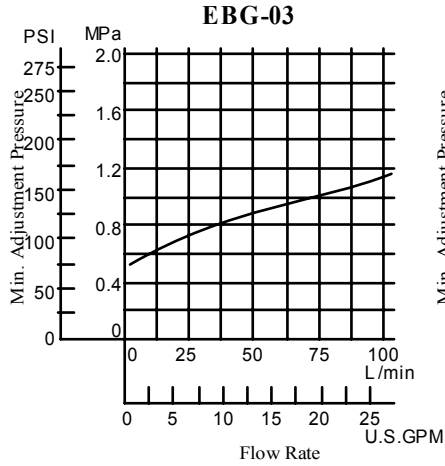

■ Step Response (Example)

These Characteristics have been obtained by measuring on each valve. Therefore, they may vary according to a hydraulic circuit to be used.

Trapped Oil Volume : 1 L (.264 U.S. Gallons)
Viscosity : 30 mm²/s (141 SSU)

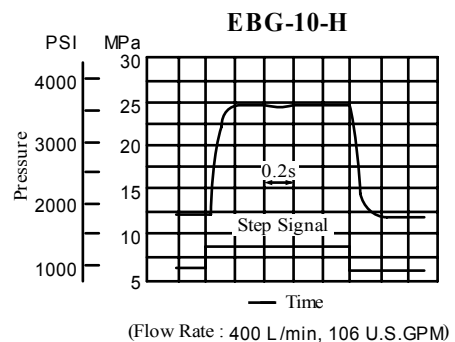
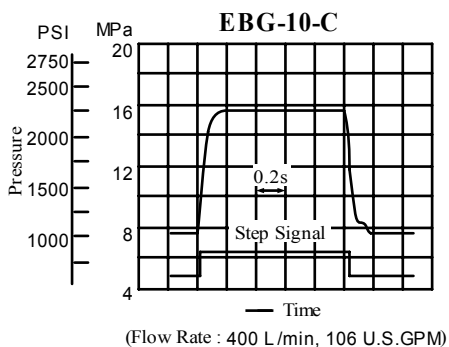
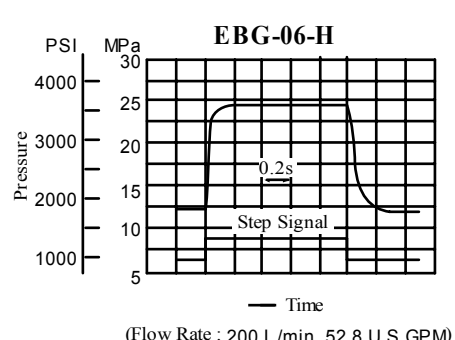
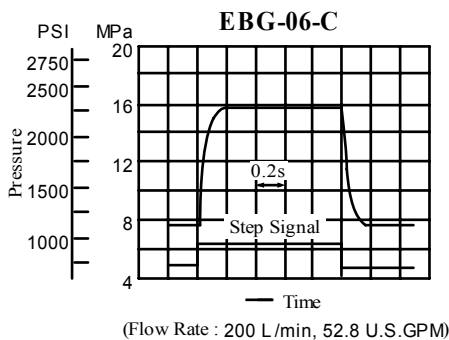
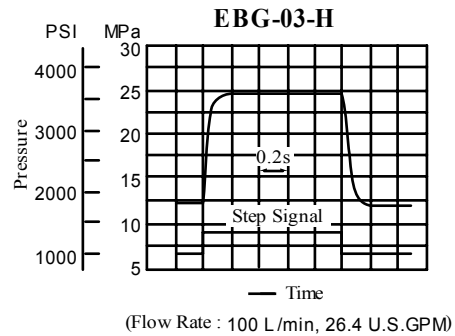
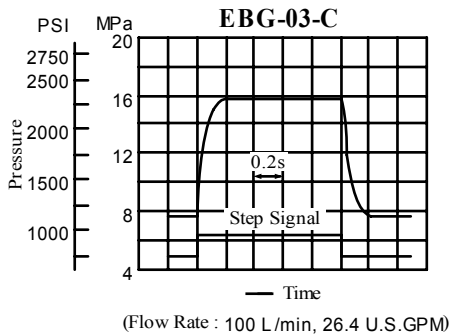

Typical Performance Characteristics

■ Input Current vs. Pressure

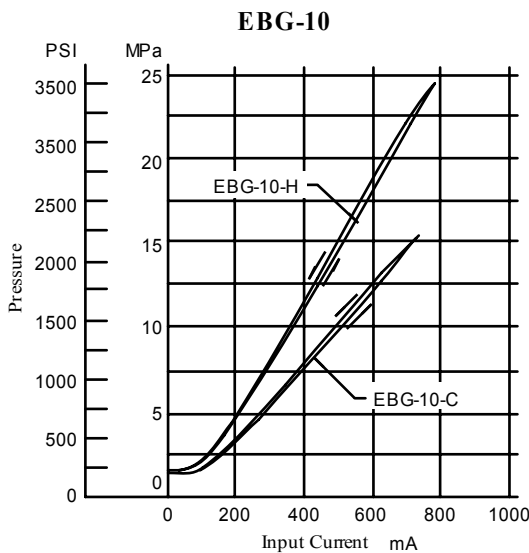
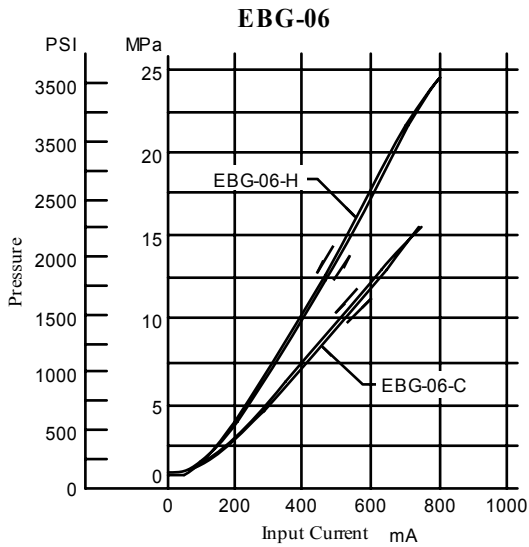
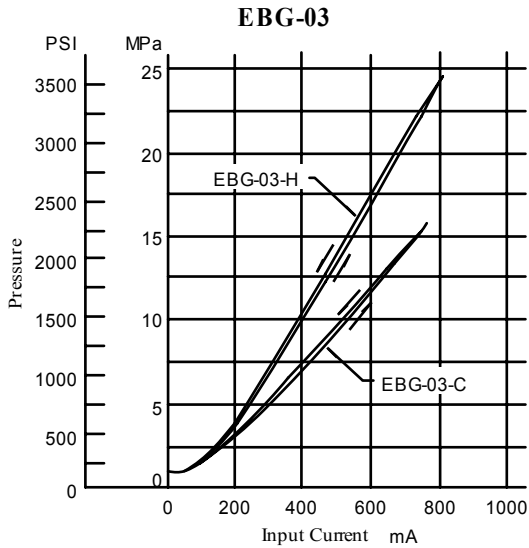

■ Frequency Response

Trapped Oil Volume : 1 L (.264 U.S. Gallons)
Viscosity : 30 mm²/s (141 SSU)

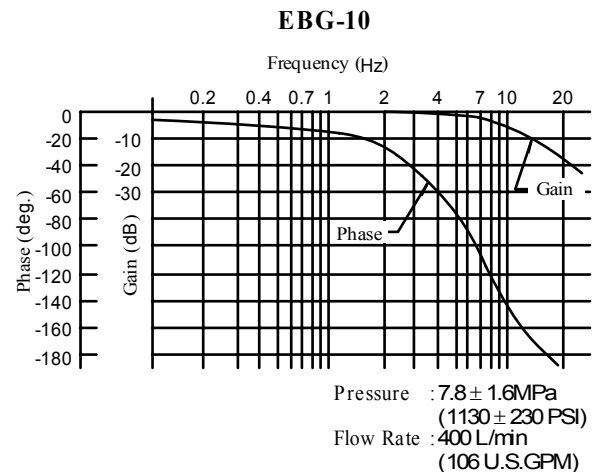
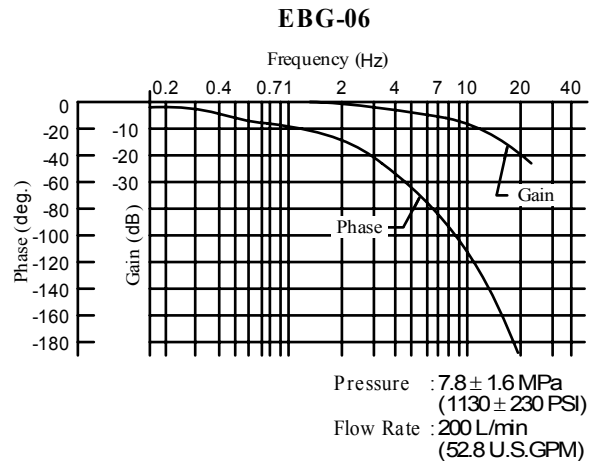
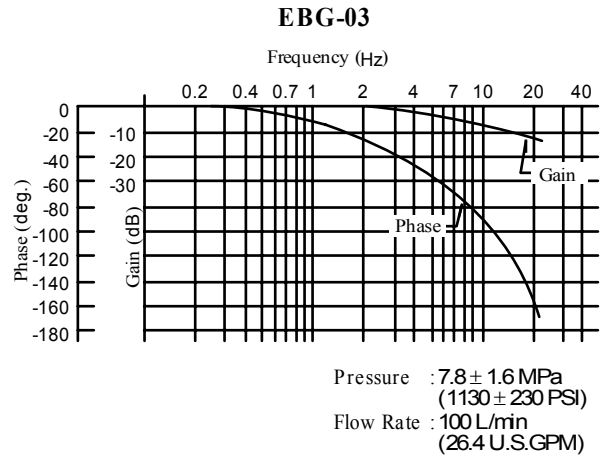

Typical Performance Characteristics

■ Viscosity vs. Pressure

Oil : ISO VG 46 Oil

■ Flow Rate vs. Pressure

Viscosity : 30 mm²/s (141 SSU)

EBG-03

Flow Rate : 100 L/min
(26.4 U.S.GPM)

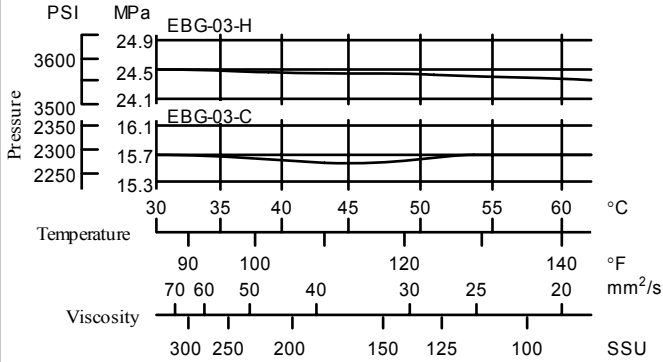

EBG-03

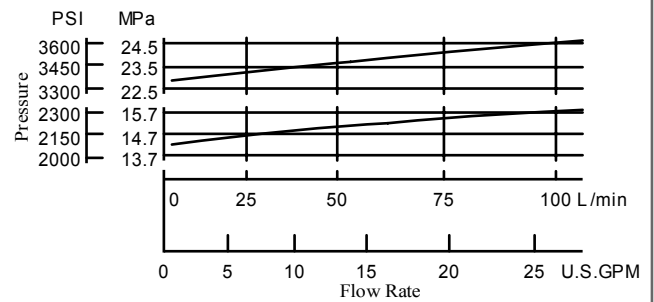

EBG-06

Flow Rate : 200 L/min
(52.8 U.S.GPM)

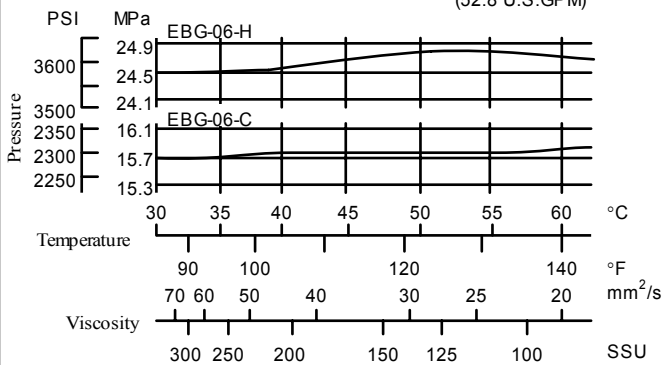

EBG-06

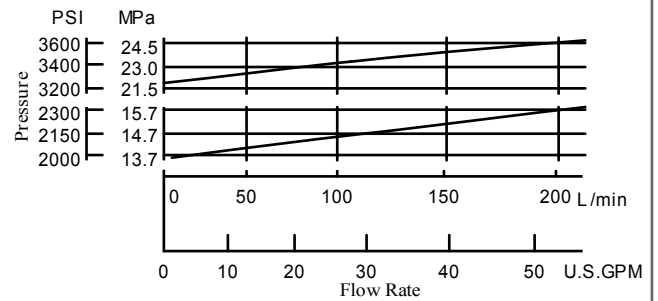

EBG-10

Flow Rate : 400 L/min
(106 U.S.GPM)

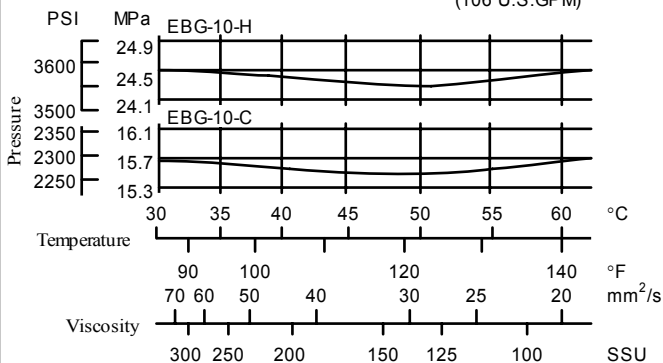

EBG-10

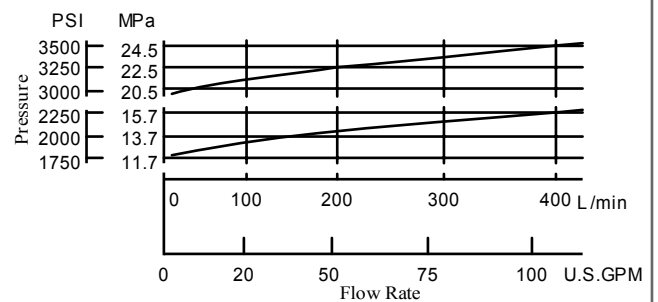

Spare Parts List

03
EBG-06-*-*-51/5190
10

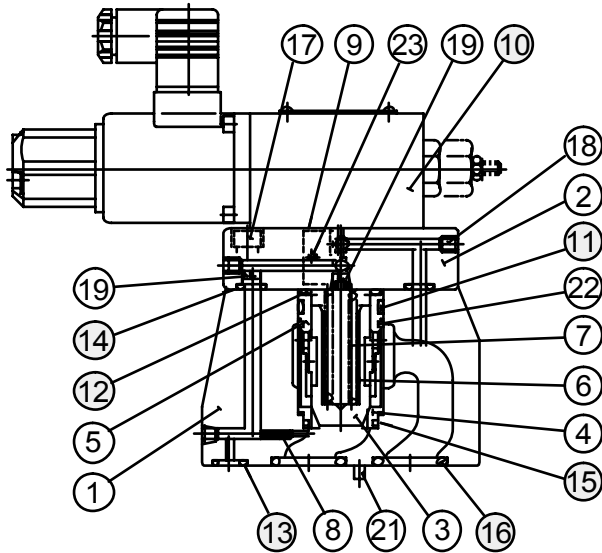

● Pilot Valve

Valve Model Numbers	Ⓒ Pilot Valve Model Numbers
EBG-03-C-51/5190	EDG-01V-C-1-PNT09-51
EBG-03-H-51/5190	EDG-01V-H-1-PNT09-51
EBG-03-C-T-51/5190	EDG-01V-C-PNT09-51
EBG-03-H-T-51/5190	EDG-01V-H-PNT09-51
EBG-06-C-51/5190	EDG-01V-C-1-PNT10-51
EBG-06-H-51/5190	EDG-01V-H-1-PNT10-51
EBG-06-C-T-51/5190	EDG-01V-C-PNT10-51
EBG-06-H-T-51/5190	EDG-01V-H-PNT10-51
EBG-10-C-51/5190	EDG-01V-C-1-PNT11-5103
EBG-10-H-51/5190	EDG-01V-H-1-PNT11-5103
EBG-10-C-T-51/5190	EDG-01V-C-PNT11-5103
EBG-10-H-T-51/5190	EDG-01V-H-PNT11-5103

Note: For the details of pilot valves, refer to "Pilot Relief Valves" on page 9.

● List of Seals

Item	Name of Parts	Part Numbers			Qty.
		EBG-03	EBG-06	EBG-10	
11	O-Ring	SO-NB-P32	SO-NB-P32	SO-NB-P42	1
12	O-Ring	SO-NB-P28	SO-NB-P28	SO-NB-P28	1
13	O-Ring	SO-NB-P9	SO-NB-P11	SO-NB-P9	1
14	O-Ring	SO-NB-P9	SO-NB-P9	SO-NB-P9	2
15	O-Ring	SO-NB-A024	SO-NB-A024	SO-NB-A128	1
16	O-Ring	SO-NB-P18	SO-NB-P28	SO-NB-P32	2

Note) When ordering seals, please specify the seal kit number from the table below.
In addition to the above O-rings, O-rings for pilot valve are included in the seal kit.
For the details of the pilot valve seals, see page 9.

● List of Seal Kit

Model Numbers	Seal Kit Numbers
EBG-03	KS-EBG-03-51
EBG-06	KS-EBG-06-51
EBG-10	KS-EBG-10-51



CAUTION

When making replacement of seals, please do it carefully after reading through the relevant instructions in the Operator's Manual.

Interchangeability between Current and New

■ Interchangeability between Current and New Design

EBG-03/06/10 series valves have changed model from 50 to 51 design in line with the model change of pilot valve (EDG-01).

● Specifications and Characteristics

No change in specifications and characteristics between current and new design.

● Mounting Interchangeability

There is an interchangeability in the mounting dimensions, however, the outside shape and dimensions are changed as shown below due to pilot valve improvement and other modifications.

Current: Design 50

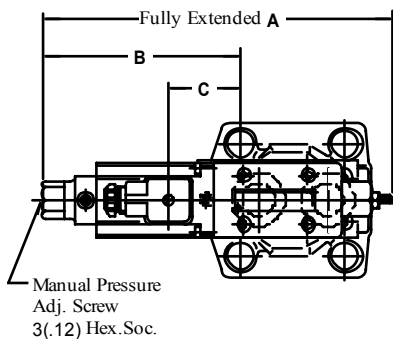

New: Design 51

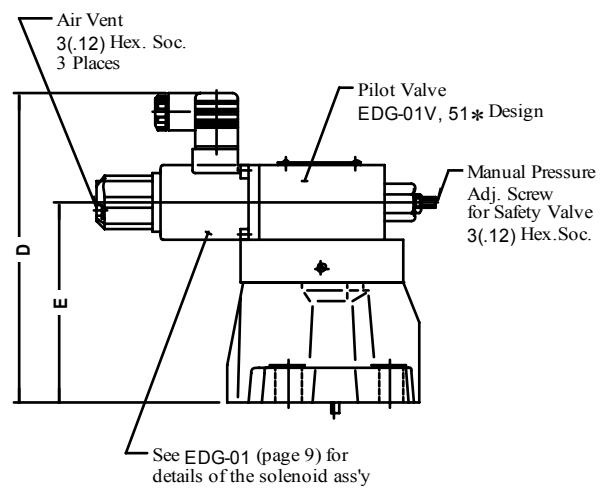
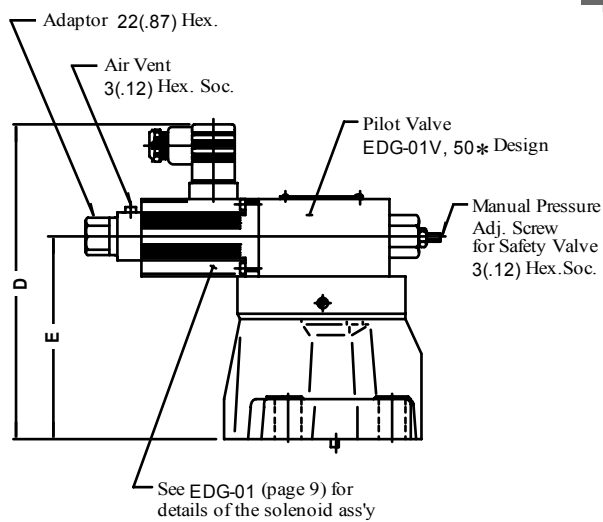
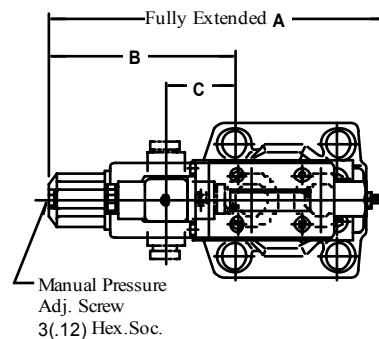

Model Numbers		A	B	C	D	E
Current	EBG-03-*-*50/5090	217 (8.54)	118.6 (4.67)	40.2 (1.58)	199.5 (7.85)	130 (5.12)
New	EBG-03-*-*51/5190	216 (8.50)	117.6 (4.63)	40.3 (1.59)		
Current	EBG-06-*-*50/5090	217 (8.54)	120.5 (4.74)	42.1 (1.66)	199.5 (7.85)	130 (5.12)
New	EBG-06-*-*51/5190	216 (8.50)	119.5 (4.70)	42.2 (1.66)		
Current	EBG-10-*-*50/5090	217 (8.54)	102 (4.02)	23.6 (.93)	235.5 (9.27)	166 (6.54)
New	EBG-10-*-*51/5190	216 (8.50)	101 (3.98)	23.7 (.93)		

DIMENSIONS IN
MILLIMETRES (INCHES)

Specifications / Model Number Designation

■ Specifications

Model Numbers Description	ERBG-06	ERBG-10
Max. Operating Pres. MPa (PSI)	24.5 (3550)	24.5 (3550)
Max. Flow L/min(U.S.GPM)	100 (26.4)	250 (66)
Max. Relieving Flow L/min(U.S.GPM)	35 (9.24)*	15 (3.96)*
Secondary Pres. Adj. Range MPa (PSI)	Refer to Model Number Designation	
Rated Current	B: 800 mA C: 800 mA H: 950 mA	B: 800 mA C: 800 mA H: 950 mA
Coil Resistance	10 Ω	10 Ω
Hysteresis	Less than 3%	Less than 3%
Repeatability	Less than 1%	Less than 1%
Approx. Mass kg (lbs.)	12 (26.5)	13.5 (29.8)

★ The values shown are those obtained where the differential pressure between the secondary pressure port and tank port is 13.7 MPa (2000 PSI).

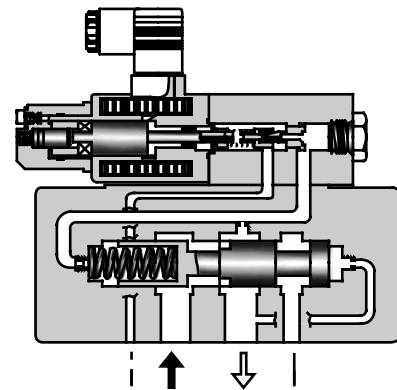
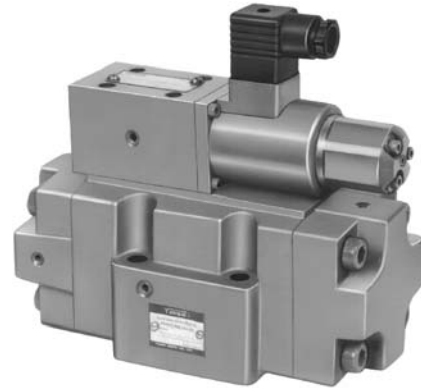

Graphic Symbol

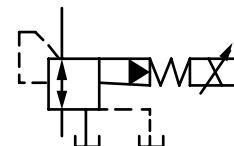

■ Model Number Designation

ERB	G	-06	-C	-51	*
Series Number	Type of Mounting	Valve Size	Secondary Pres. Adj. Range MPa (PSI)	Design Number	Design Standards
ERB: Proportional Electro-Hydraulic Reducing and Relieving Valve	G: Sub-plate Mounting	06	B: 0.8 - 6.9 (115 - 1000) C: 1.2 - 13.7 (175 - 2000) H: 1.5 - 20.6 (220 - 3000)	51	Refer to ★
		10	B: 0.9 - 6.9 (130 - 1000) C: 1.2 - 13.7 (175 - 2000) H: 1.5 - 20.6 (220 - 3000)		

★ Design Standards: None Japanese Standard "JIS" and European Design Standard
90 N. American Design Standard



■ Attachment

● Mounting Bolts

Valve Model Numbers	Socket Head Cap Screw		
	Japanese Standard "JIS" & European Design Standard	N. American Design Standard	Qty.
ERBG-06	M10 ×70 Lg.	3/8 - 16 UNC ×2-3/4 Lg.	4
ERBG-10	M10 ×70 Lg.	3/8 - 16 UNC ×2-3/4 Lg.	6

■ Applicable Power Amplifier

For stable performance, it is recommended that Yuken's applicable power amplifiers be used (for details see Catalogue No. Pub. EC-1305).

- Model Numbers: AME-D-10-* -20
 AME-D2-1010-* -10
 SK1022-* -*-11
 SK1015-11 (For DC power supply)
 AMN-D-10 (For DC power supply)

■ Sub-plate

Valve Model Numbers	Japanese Standard "JIS"		European Design Standard		N. American Design Standard		Approx. Mass kg (lbs.)
	Sub-plate Model Numbers	Thread Size	Sub-plate Model Numbers	Thread Size	Sub-plate Model Numbers	Thread Size	
ERBG-06	ERBGM-06-20	Rc 3/4	ERBGM-06-2080	3/4 BSP.F	ERBGM-06-2090	3/4 NPT	3.0 (6.6)
ERBG-10	ERBGM-10-10	Rc 1-1/4	ERBGM-10-1080	1-1/4 BSP.F	ERBGM-10-1090	1-1/4 NPT	6.5 (14.3)

- Sub-plates are available. Specify the sub-plate model number from the table above. When sub-plates are not used, the mounting surface should have a good machined finish.

■ Instructions

● Primary Pressure Required for Preselected Pressure

The primary pressure must be 1 MPa (145 PSI) higher than the preselected pressure.

● Drain Back Pressure

Check that the drain back pressure does not exceed 0.2 MPa (29 PSI).

● Trapped Oil Volume

The recommended secondary side trapped oil volume is about 20 liters (5.28 U.S.Gallons). Note that the trapped oil volume must not be lower than 1.4 liters (.37 U.S.Gallons).

Installation Drawing

Sub-plate:

ERBGM-06-20/2080/2090

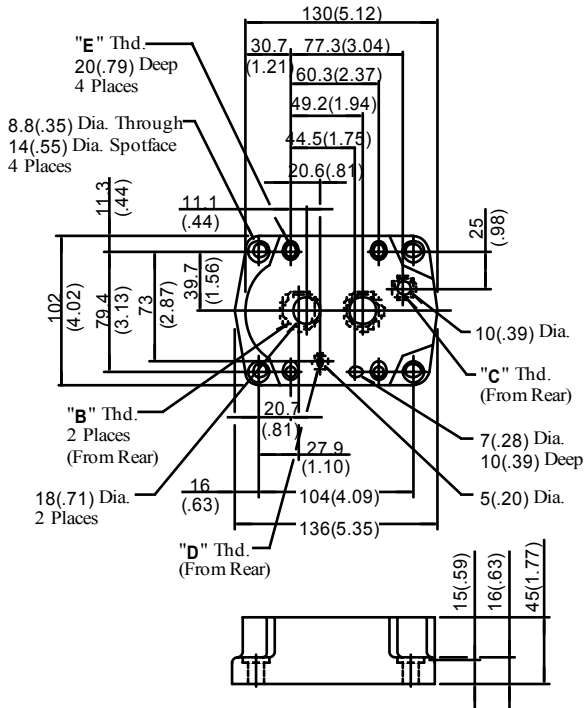

Sub-plate Model Numbers	Thread Size			
	"B" Thd.	"C" Thd.	"D" Thd.	"E" Thd.
ERBGM-06-20	Rc 3/4	Rc 3/8	Rc 1/4	M10
ERBGM-06-2080	3/4 BSP.F	3/8 BSP.F	1/4 BSP.F	
ERBGM-06-2090	3/4 NPT	3/8 NPT	1/4 NPT	

DIMENSIONS IN
MILLIMETRES (INCHES)

ERBG-06-* -51/5190

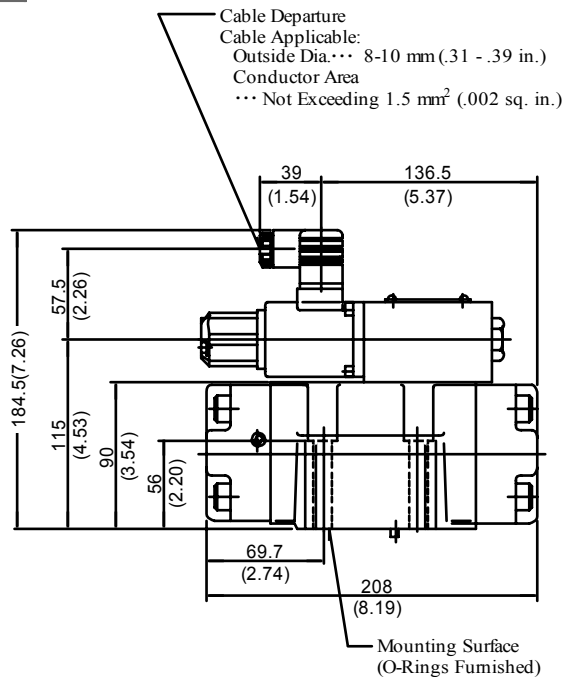
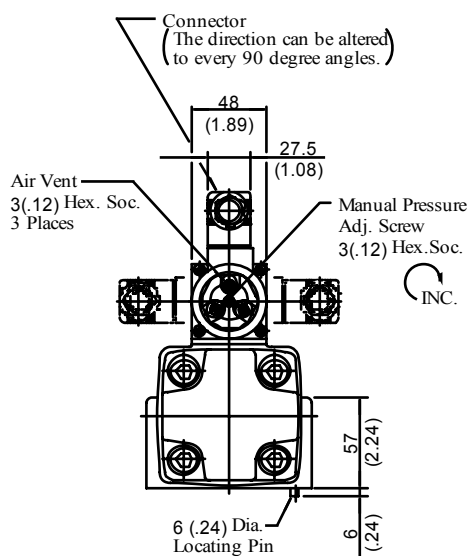
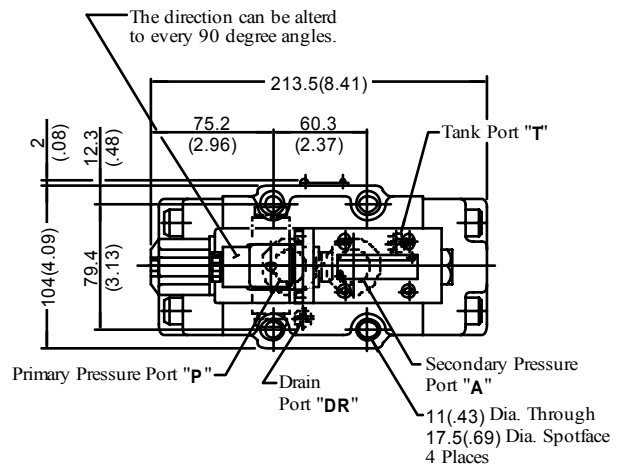

Installation Drawing

Sub-plate:
ERBGM-10-10/1080/1090

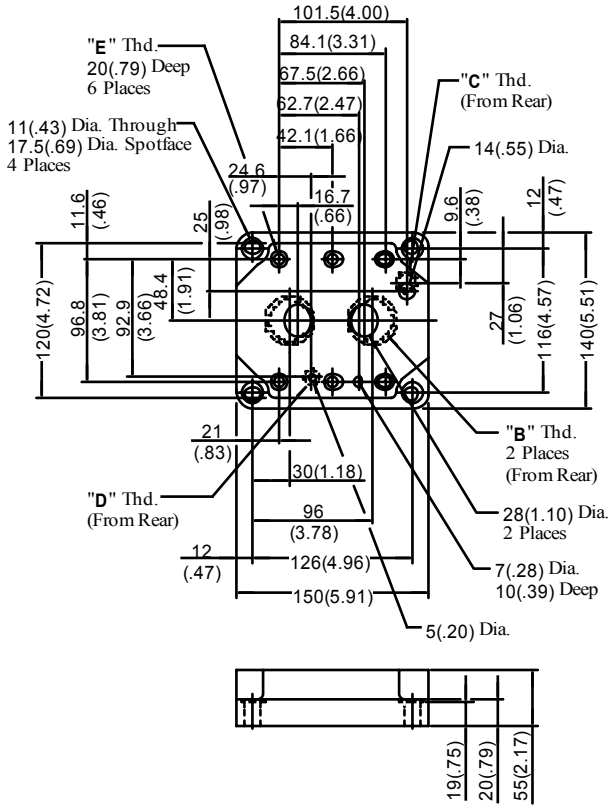

DIMENSIONS IN
MILLIMETRES (INCHES)

ERBG-10-* -51/5190

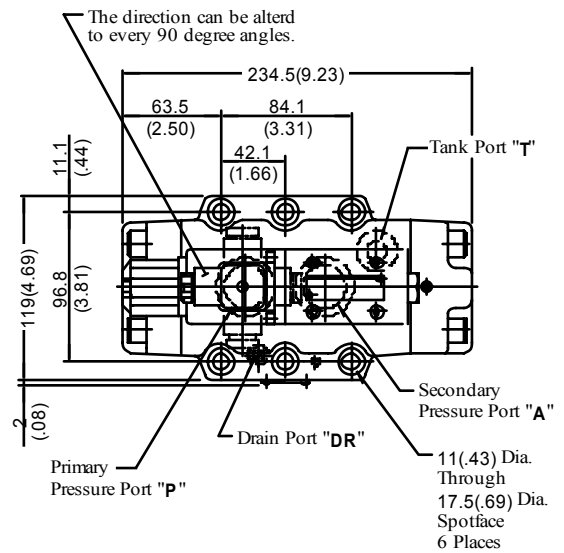

Sub-plate Model Numbers	Thread Size			
	"B" Thd.	"C" Thd.	"D" Thd.	"E" Thd.
ERBGM-10-10	Rc 1-1/4	Rc 3/8	Rc 1/4	M10
ERBGM-10-1080	1-1/4 BSP.F	3/8 BSP.F	1/4 BSP.F	
ERBGM-10-1090	1-1/4 NPT	3/8 NPT	1/4 NPT	

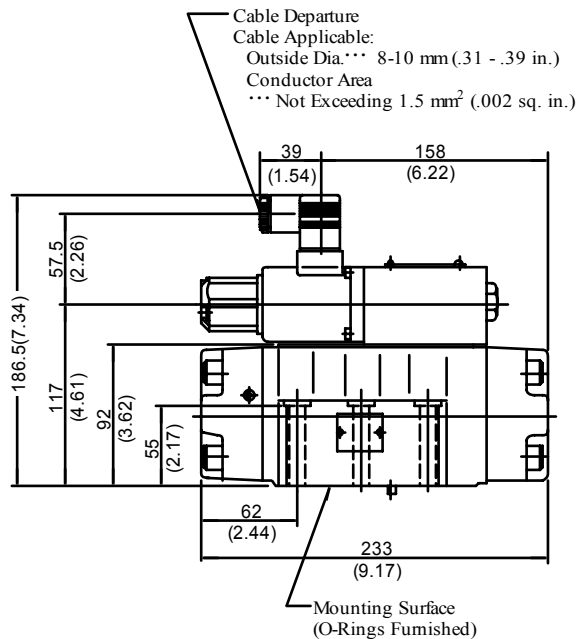
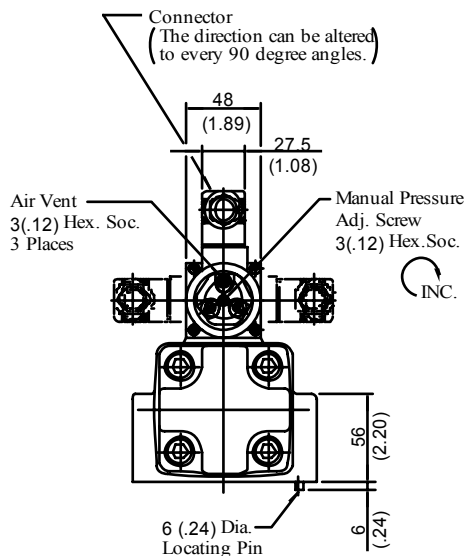

Typical Performance Characteristics

■ Step Response (Example)

The following step response characteristics are taken when the trapped oil volume is 20 liters (5.28 U.S.Gallons).
The step response varies by trapped oil volume.

Primary Pressure : 24.5 MPa (3550 PSI)
Trapped Oil Volume : 20 L (5.28 U.S.Gallons)
Viscosity : 30 mm²/s (141 SSU)

ERBG-06-B

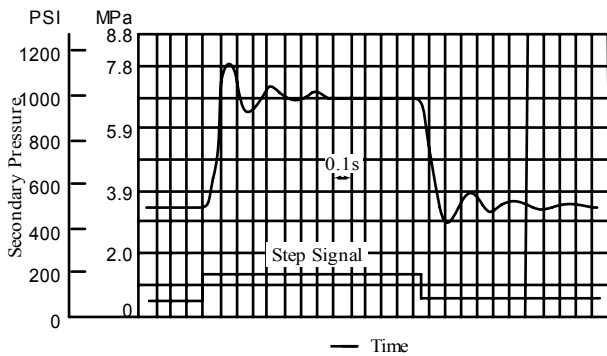

ERBG-10-B

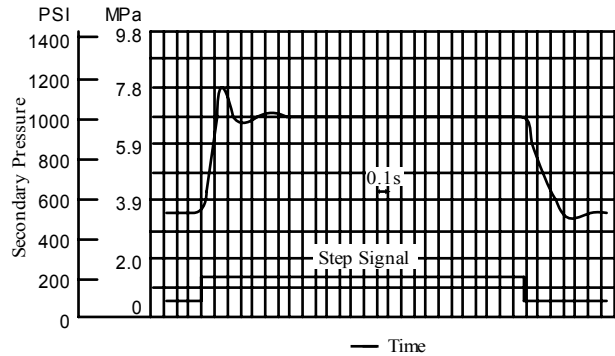

ERBG-06-C

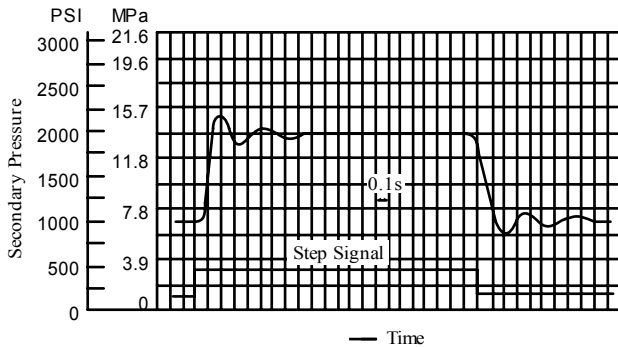

ERBG-10-C

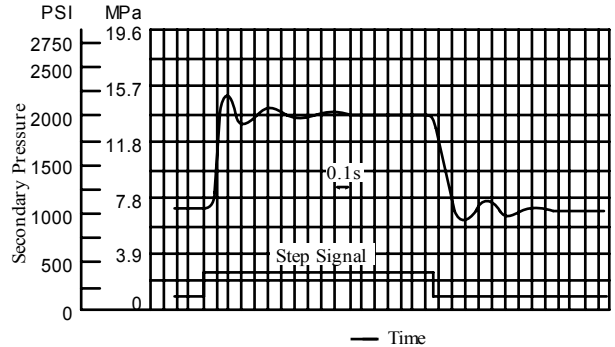

ERBG-06-H

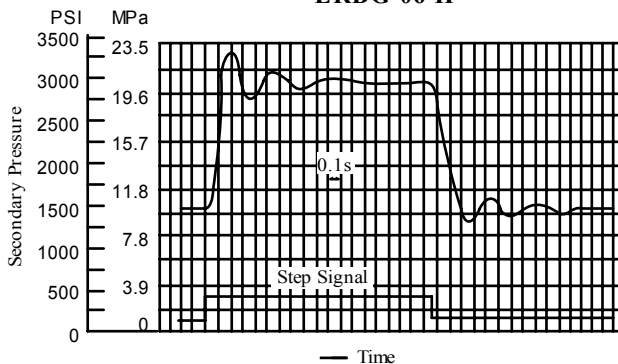

ERBG-10-H

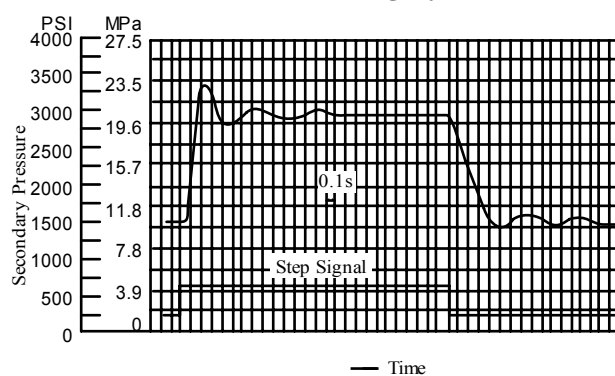

Typical Performance Characteristics

Input Current vs. Secondary Pressure

Primary Pressure 24.5 MPa (3550 PSI)
Viscosity : 30 mm²/s (141 SSU)

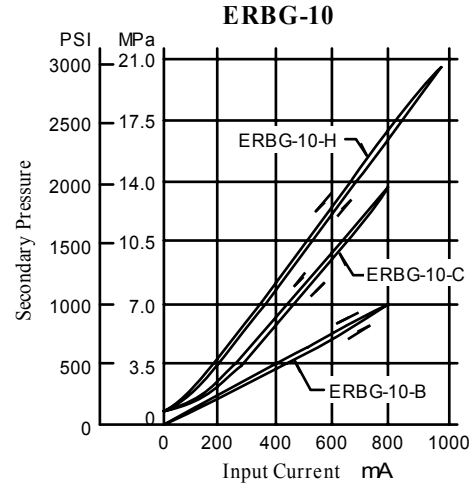
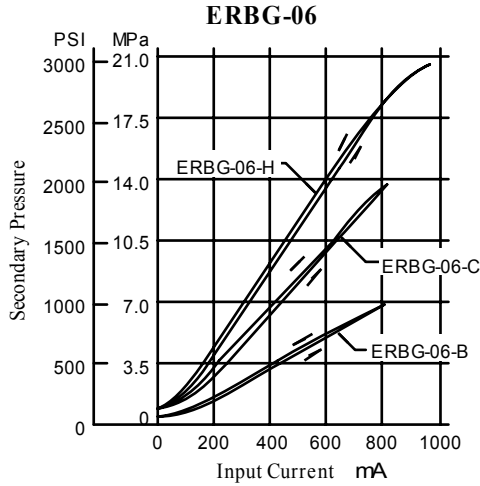

Frequency Response

Primary Pressure : 24.5 MPa (3550 PSI)
Trapped Oil Volume: 20 L (5.28 U.S.Gallons)
Viscosity : 30 mm²/s (141 SSU)

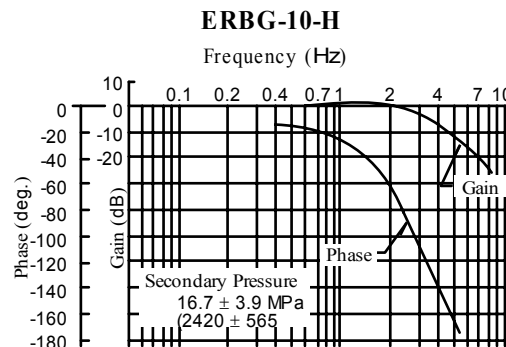
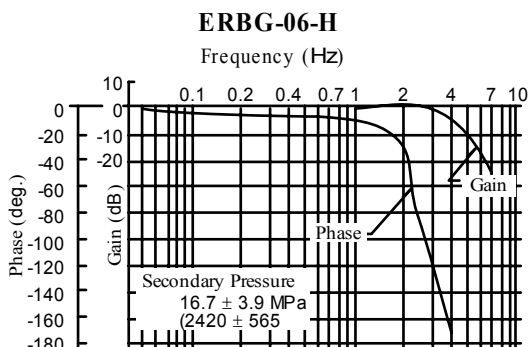
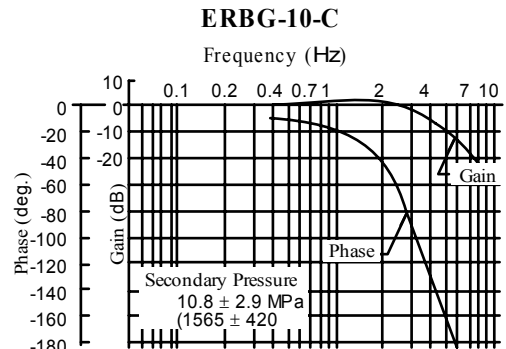
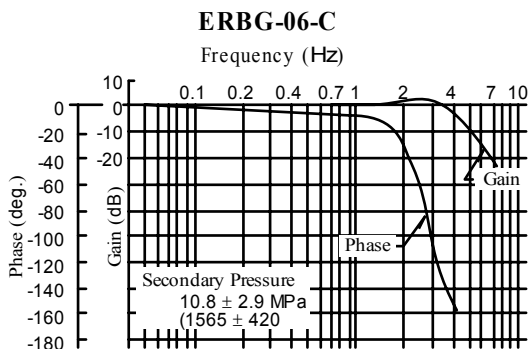
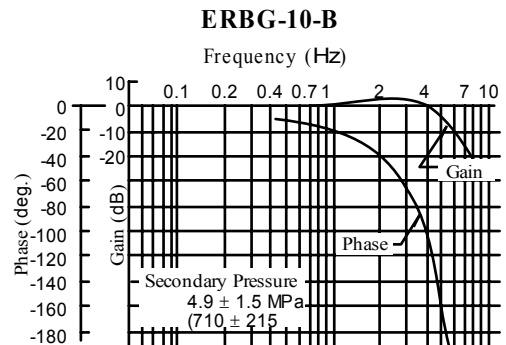
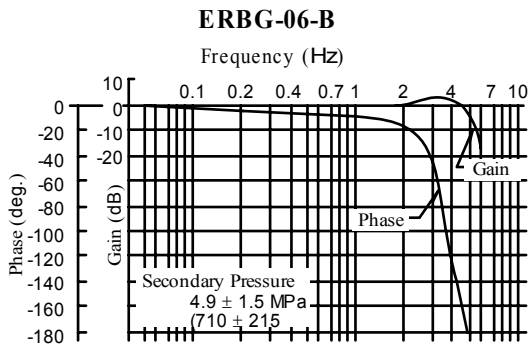

Typical Performance Characteristics

■ Flow Rate vs. Secondary Pressure

Viscosity: 30 mm²/s (141 SSU)

ERBG-06-B

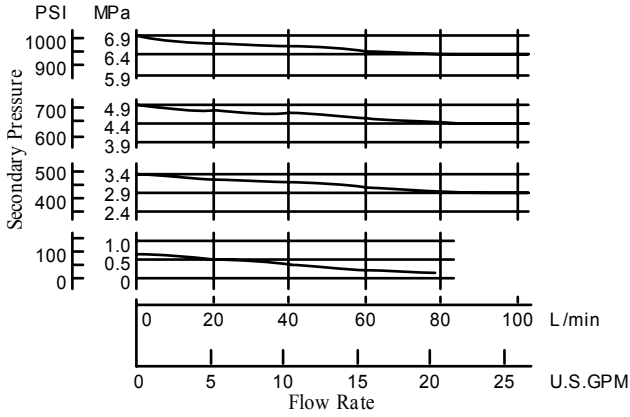

ERBG-10-B

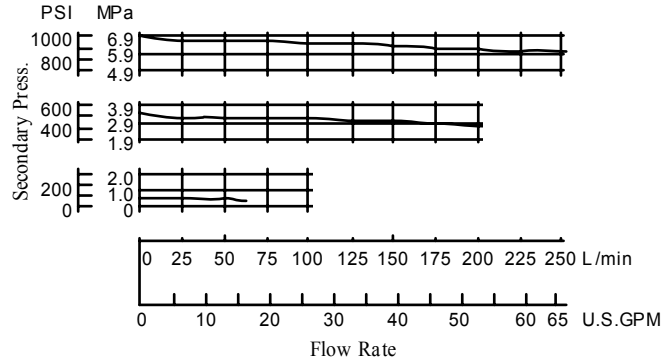

ERBG-06-C

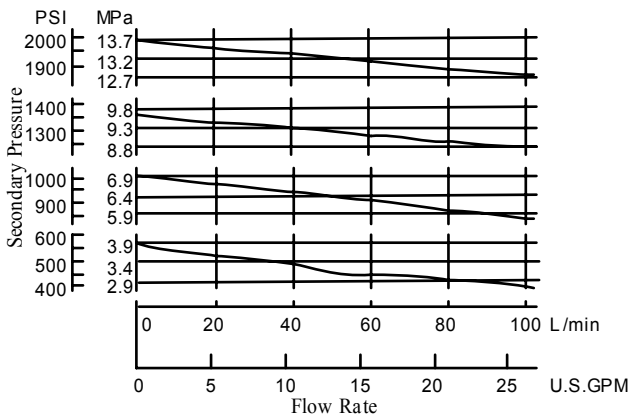

ERBG-10-C

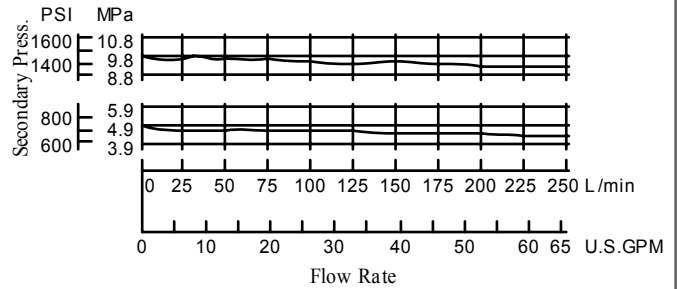

ERBG-06-H

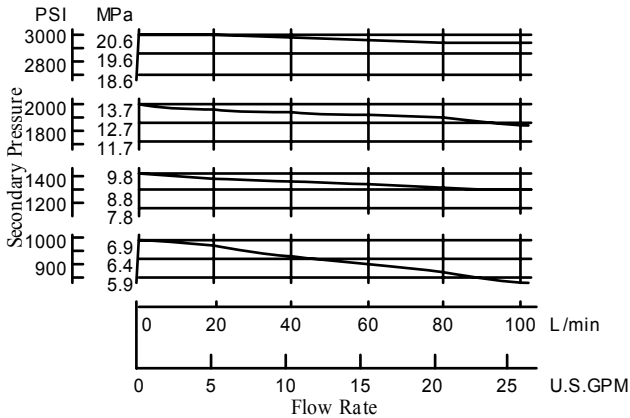

ERBG-10-H

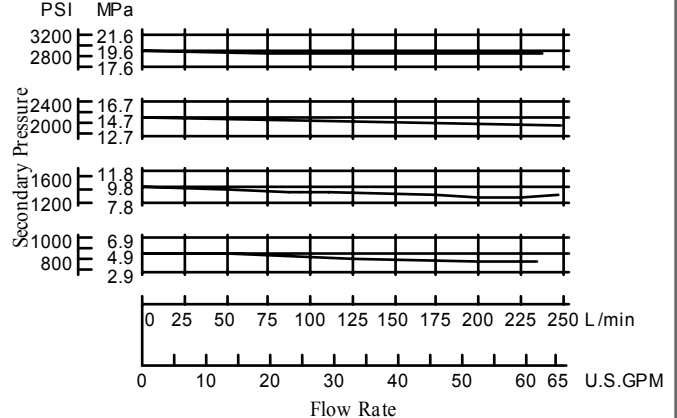

Typical Performance Characteristics

■ Viscosity vs. Secondary Pressure

ERBG-06-B

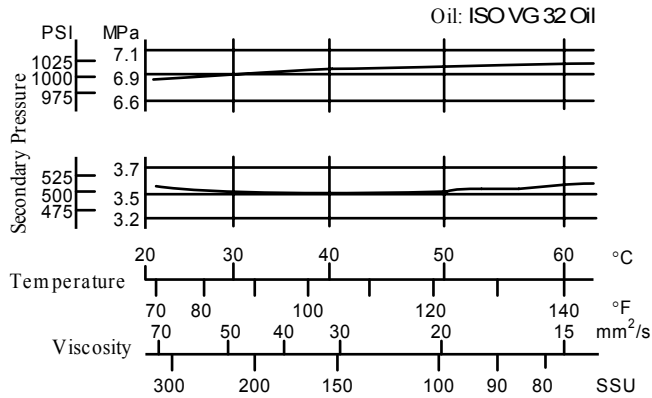

ERBG-10-B

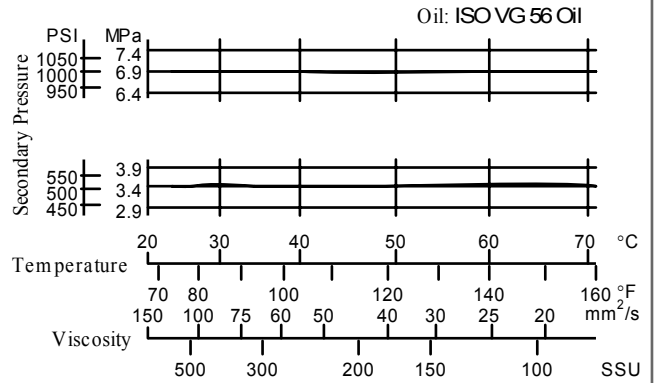

ERBG-06-C

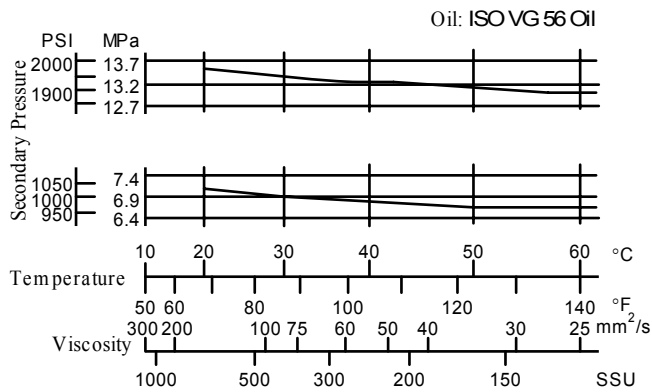

ERBG-10-C

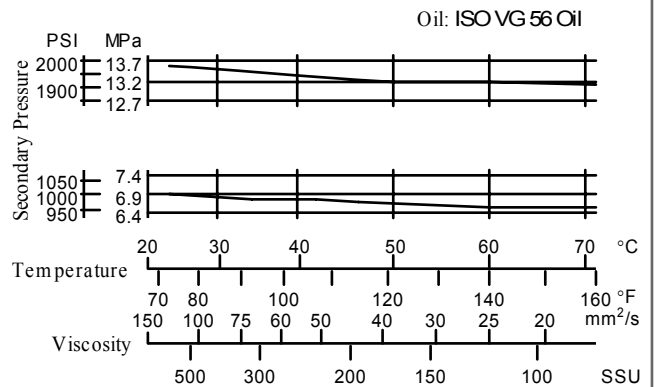

ERBG-06-H

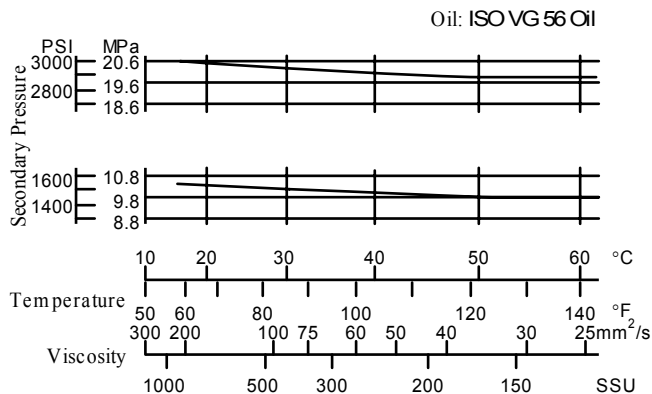

ERBG-10-H

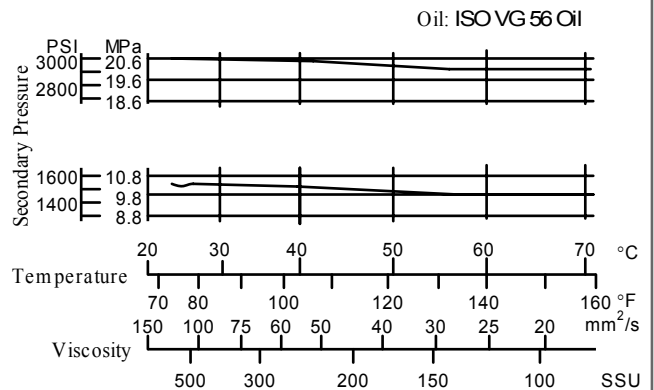

Spare Parts List

■ Spare Parts List

ERBG- 06
10 * -51/5190

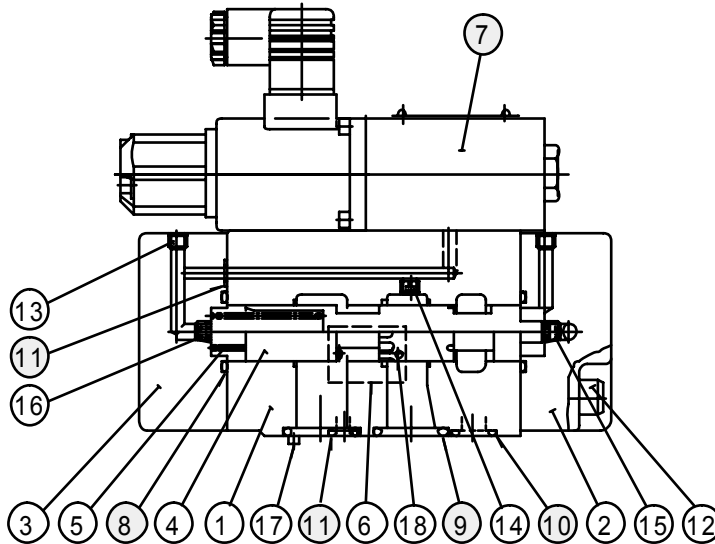

● List of Seals

Item	Name of Parts	Part Numbers		Qty.
		ERBG-06	ERBG-10	
8	O-Ring	SO-NB-G30	SO-NB-P36	2
9	O-Ring	SO-NB-P28	SO-NB-P32	2
10	O-Ring	SO-NB-P14	SO-NB-P18	1
11	O-Ring	SO-NB-P9	SO-NB-P9	3

Note) When ordering seals, please specify the seal kit number from the table right. In addition to the above O-rings, O-rings for pilot valve are included in the seal kit.
For the details of the pilot valve seals, see page 9.

● Pilot Valve

Valve Model No.	⑦ Pilot Valve Model Numbers
ERBG-06-B-51/5190	EDG-01-B-PNTN-5101
ERBG-06-C-51/5190	EDG-01-C-PNTN-5101
ERBG-06-H-51/5190	EDG-01-H-PNT15-5101
ERBG-10-B-51/5190	EDG-01-B-PNTN-5101
ERBG-10-C-51/5190	EDG-01-C-PNTN-5101
ERBG-10-H-51/5190	EDG-01-H-PNT15-5101

Note: For the details of pilot valves, refer to "Pilot Relief Valves" on page 9.

● List of Seal Kits

Model Numbers	Seal Kit Numbers
ERBG-06	KS-ERBG-06-51
ERBG-10	KS-ERBG-10-51



CAUTION

When making replacement of seals, please do it carefully after reading through the relevant instructions in the Operator's Manual.

Interchangeability between Current and New

■ Interchangeability between Current and New Design

ERBG-06/10 series valves have changed model from 50 to 51 design in line with the model change of pilot valve (EDG-01).

● Specifications and Characteristics

No change in specifications and characteristics between current and new design.

● Mounting Interchangeability

There is an interchangeability in the mounting dimensions, however, the outside shape and dimensions are changed as shown below due to pilot valve improvement and other modifications.

Current: Design 50

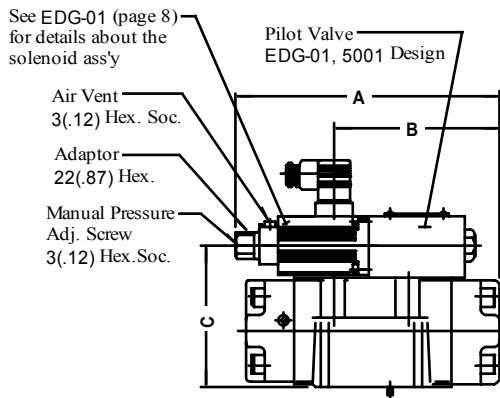

New: Design 51

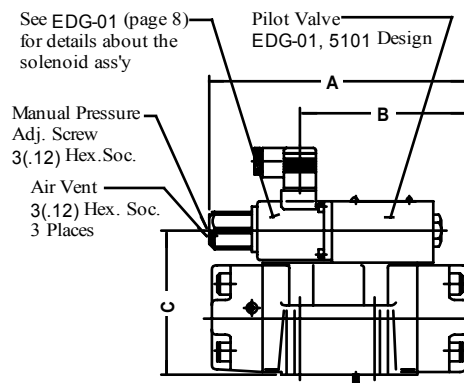

Model Numbers		A	B	C
Current	ERBG-06-* -50/5090	214.5 (8.44)	136.5 (5.37)	115 (4.53)
New	ERBG-06-* -51/5190	213.5 (8.41)	136.5 (5.37)	115 (4.53)
Current	ERBG-10-* -50/5090	235.5 (9.27)	158 (6.22)	117 (4.61)
New	ERBG-10-* -51/5190	234.5 (9.23)	158 (6.22)	117 (4.61)

DIMENSIONS IN
MILLIMETRES (INCHES)